

Current State Assessment & Existing Measurement Technology Review Report

CASCADE GATEWAY ADVANCED BORDER INFORMATION SYSTEM (ABIS) DESIGN PROJECT



whatcom council of governments

April 16, 2024

Prepared By:



Transpo Group USA, Inc.
12131 113th Avenue NE, Suite 203
Kirkland, WA 98034-7120
Phone: 425-821-3665
www.transpogroup.com



Texas A&M Transportation Institute
3135 TAMU
College Station, Texas 77843-3135
Phone: (979) 317-2000
tti.tamu.edu



Sarakki Associates Inc.
4199 Campus Drive, Ste 550
Irvine, CA 92612
Phone: 949-825-7046
www.sarakki.com

TABLE OF CONTENTS

1. Introduction	3
2. Current State Assessment.....	4
2.1 Introduction	4
2.2 Existing System Overview	6
2.2.1 System Stakeholders.....	6
2.2.2 Southbound ATIS.....	7
2.2.3 Northbound ATIS.....	9
2.2.4 Cascade Gateway Border Data Warehouse	11
2.2.5 Existing System Components.....	13
2.2.6 Existing System Challenges and User Needs.....	24
2.3 Planned Projects	32
3. Existing Measurement Technology Review.....	34
3.1 Introduction	34
3.2 Border Wait Time Measurement System Definitions.....	34
3.2.1 Wait Times and Crossing Times	34
3.2.2 Approaches to Measuring BWT	35
3.3 Technologies Overview	37
3.3.1 Data Collection and Traffic Monitoring Technologies	37
3.3.2 Border Wait Time Data Transmission Technologies	53
3.3.2 Information Dissemination Mechanisms and Technologies.....	54
3.3.3 Data Storage, Archiving and Reporting	56
3.4 State of the Practice Review (and Case Studies).....	59
3.4.1 State of the Practice at the U.S-Canada Border.....	59
3.4.2 State of the Practice at the U.S-Mexico Border.....	60
3.5 Conclusion.....	73
4. References	78



1. INTRODUCTION

In 2023, the Whatcom Council of Governments (WCOG) was awarded funding through Stage 1 of the Strengthening Mobility and Revolutionizing Transportation (SMART) Grants Program. This program, funded through the Bipartisan Infrastructure Law (BIL) and administered through the U.S. Department of Transportation (USDOT), funds purpose-driven innovation to build data and technology capacity and expertise for State, local, and Tribal governments, with the goal of using new technologies and approaches to target real-world challenges and create benefits. The program is structured in two stages, in which applicants initially seek Stage 1 Planning and Prototyping Grants. Selected projects are then eligible to apply for Stage 2 Implementation Grants, for which the Notice of Funding Opportunity is expected to be issued in Summer 2024. The purpose of this Stage 1 project is to identify technology options and to develop a complete implementation plan with cost estimates for a new Cascade Gateway Advanced Border Information System (ABIS). The existing system, known as the Advanced Traveler Information System (ATIS), is 20 years old with ageing hardware and software systems. As such, this Stage 1 project involves design only, and the ABIS will not be fully implemented until Stage 2 funding is secured.

This document, prepared as part of the Cascade Gateway ABIS Design Project, is divided into two parts: Section 2 focuses on the Current State Assessment (including the existing ATIS and Cascade Gateway Border Data Warehouse), including a summary of the user needs that have been preliminarily collected to date, while Section 3 provides an overview of existing Border Wait Time (BWT) measurement technologies.

The purpose of Section 2 is to document the existing northbound ATIS (operated by the Washington State Department of Transportation [WSDOT]) and southbound ATIS (operated by the British Columbia Ministry of Transportation and Infrastructure [BCMOTI]), including the existing designs, equipment, functionality, and accuracy. Additionally, it aims to develop a comprehensive list of existing challenges and identify areas that need to be addressed in the new ABIS. To this end, this report includes a review of the systems' details and available documentation, insights gathered from site visits of the existing systems, and findings from the kick-off meeting and discussions with key stakeholders, during which initial user needs were identified. These activities took place on-site at each of the four crossings between December 12-13, 2023.

Furthermore, Section 3 includes a review of the state-of-the-practice regarding BWT measurement technologies, including case studies from other U.S.-Canada and U.S.-Mexico border crossings.

By examining the current state of the existing ATIS, assessing user needs, and reviewing BWT technologies that are available or have been deployed at other locations, this document aims to lay the groundwork for informed decision-making and the development of an enhanced ABIS. A listing of the documentation reviewed as part of this effort is included in Section 4.

2. CURRENT STATE ASSESSMENT

One of the initial tasks of this project was to conduct a comprehensive review of the existing conditions to gain a complete, current, and accurate understanding of the ATIS, which is imperative for informing the systems engineering process for the new ABIS. This task involved several steps, including:

- Review of system documentation and as-built drawings to understand the hardware and software currently deployed;
- Review of reports and planning documents to quantify issues related to data accuracy and reliability, supplemented with data collection and field studies;
- Site surveys of existing Ports-Of-Entry (POE) to understand infrastructure, technologies, and operational characteristics such as traffic conditions and queuing patterns, covering approaches to each POE; and
- Site visits to all four POEs on both sides of the border to gain familiarity with equipment, operations, and system components and to identify gaps in the existing system.

In addition to these assessments, a kick-off meeting was held on December 12, 2023 to begin engaging with stakeholders who have been involved with the ATIS and will continue to be involved with the ABIS, including WSDOT, BCMOTI, U.S. Customs & Border Protection (USCBP), Canadian Border Services Agency (CBSA), and WCOG. A meeting was also conducted with Arcadis/IBI Group on February 15, 2024, the developers of the Cascade Gateway Border Data Warehouse, to better understand the existing system.

Additional meetings with project stakeholders were held on February 28-29, 2024 to continue the stakeholder engagement process, along with additional site visits on February 29, 2024 and March 1, 2024 that further evaluated on-site infrastructure, including potential equipment installation locations, and the physical geometry of the POEs.

2.1 Introduction

The Cascade Gateway system of border crossings consists of four land POEs connecting the Lower Mainland in British Columbia and Whatcom County in Washington State. To optimize traffic flow across the Cascade Gateway POEs and to provide travelers with real-time traveler information on nearby cross-border routes, WSDOT and BCMOTI each installed a northbound and southbound ATIS, respectively, at all four POEs. Since 2007, both systems have exported their data in real-time to an online archive at www.borderdata.org.

Currently, the operating hours and lane types at each border crossing are as follows:

- **Peace Arch/Douglas:** Open 24 hours for passenger traffic and NEXUS, serving U.S. I-5 and B.C. Hwy 99.
- **Pacific Highway:** Open 24 hours for passenger traffic, NEXUS, buses, commercial traffic, and FAST, serving WA SR 543 and B.C. Hwy 15.
- **Lynden (Kenneth G. Ward)/Aldergrove:** Open from 8:00 am to 12:00 am for northbound passenger traffic, NEXUS, and commercial traffic, and from 8:00 am to 12:00 am for southbound passenger and permit-only trucks, serving WA SR 539 and B.C. Hwy 13.
- **Sumas/Abbotsford-Huntingdon:** Open 24 hours for passenger traffic, NEXUS, and commercial traffic, serving WA SR 9 and B.C. Hwy 11.

Both systems utilize primarily loop detectors to collect data in real-time to estimate current wait times. This data includes vehicle counts and speeds, estimated queue end locations, the number of inspection booths open,

and the current average inspection booth processing rate. Separate algorithms for WSDOT and BCMOTI calculate the estimated wait time, which is transmitted through a combination of fiber optic and wireless communication systems between the roadside, WSDOT and BCMOTI Traffic Management Centers (TMC), and the Cascade Gateway Border Data Warehouse.

The southbound system has been modified to include real-time booth-type data from U.S. Customs & Border Protection (USCBP). Booth type, and consequently lane type (standard or trusted-traveler), must be known for accurate wait time estimation, since processing times for NEXUS (trusted-traveler) booths and standard booths differ significantly. Although there is only one NEXUS approach lane, the number of inspection booths serving the NEXUS travelers can vary.

As the POEs and operational procedures have evolved, certain complications in the original system setup have impacted its performance. These challenges primarily relate to the accuracy and reliability of the loop detectors. When lane configurations change, the roads are paved, or when other maintenance occurs, the loop detectors may become damaged and rendered inoperable. Additionally, these detectors are not well suited to low-speed situations, typical of the stop-and-go traffic experienced at border crossings, degrading the accuracy of the data being collected. Figure 1 below provides an overview of the Cascade Gateway POEs and the types of traffic that each serves.



Figure 1. The Cascade Gateway ABIS Project Area Overview

2.2 Existing System Overview

Initially introduced in 2004, the existing ATIS is designed to monitor traffic flow and estimate wait times at the various border crossings. Originally, it primarily targeted southbound traffic near the Peace Arch/Douglas (Hwy 99) and Pacific Highway (Hwy 15) border crossings, but over time, it has undergone expansions and upgrades to accommodate additional crossings and features, such as an anti-idling system at Peace Arch/Douglas for the southbound approach. Currently, the ATIS consists of the northbound and southbound system; the northbound system is operated by WSDOT, while the southbound system is operated by BCMOTI. Each system collects traffic data using inductive loop detectors located at the POE and the approaching roadways to calculate estimated wait time information, which is then disseminated to the public through Dynamic Message Signs (DMS) or Variable Message Signs (VMS), Interactive Voice Response (VIR) system (BC MOTI only – travelers can call 604-542-4360 for an audio/voicemail system), websites, and mobile apps. In 2007, the Cascade Gateway Border Data Warehouse (BDW) was also developed, which ingests data from the northbound and southbound systems and serves as a publicly-accessible repository of historical wait times and traffic volumes.

2.2.1 System Stakeholders

As the existing system is utilized by both sides of the border, multiple stakeholders and entities are involved in its operation, data management, maintenance, and support. These entities, hailing from both the Canadian and U.S. sides, include transportation agencies, governmental bodies, border inspection agencies, and are represented by a public-private coalition called the **International Mobility & Trade Corridor (IMTC) Program**. This coalition, which also includes U.S. and Canadian businesses involved in cross-border trade, is aimed at enhancing mobility and security for the Cascade Gateway. The IMTC Program focuses on five POEs connecting western Washington state and the Lower Mainland of British Columbia, though only four are included in this project. Members and supporting entities of the IMTC include, but are not limited to the following:

- **Whatcom Council of Governments (WCOG)**, the region’s Metropolitan Planning Organization (MPO) and Regional Transportation Planning Organization (RTPO) for Whatcom County, facilitates cooperation on regional transportation issues, including administering the IMTC. Its membership encompasses Whatcom County, its seven cities, the Port of Bellingham, the Lummi Nation, and other regional entities. Additionally, WCOG manages the IMTC Program, oversees the Cascade Gateway Border Data Warehouse, and is managing this ABIS SMART Stage 1 project
- **Washington State Department of Transportation (WSDOT)** is a governmental agency that constructs, maintains, and regulates the use of transportation infrastructure in the state of Washington. It has a widely deployed network of Intelligent Transportation Systems (ITS), including VMS, CCTV cameras, data stations, weather monitoring stations, and more. WSDOT owns, operates, and maintains the existing ATIS in the northbound direction, and were the original developers of the northbound ATIS.
- **British Columbia Ministry of Transportation and Infrastructure (BCMOTI)** is the government ministry responsible for transport infrastructure and law in the province of British Columbia. BCMOTI owns, operates, and maintains the existing ATIS in the southbound direction. BCMOTI operates and maintains the (back-end) system through Arcadis/IBI Group, and maintains the (physical) system through Cobra Electric.

- **Arcadis/IBI Group** developed the original southbound ATIS and the Cascade Gateway Border Data Warehouse, and are currently serving as the contractor for operations and maintenance of those two systems.
- **U.S. Customs and Border Protection (USCBP)** oversees border security and operations for the United States, though do not directly interact with the ATIS, aside from providing booth status data to the southbound ATIS.
- **Canadian Border Services Agency (CBSA)** oversees border security and operations for Canada, though do not directly interact with the ATIS.
- **General Services Administration (GSA)** owns and manages the U.S. border stations.
- **Western Washington University's Border Policy Research Institute (BPRI)** conducts project analysis and evaluates how the system's outputs can contribute to academic research on border-related issues. BPRI is another crucial stakeholder utilizing the project outcomes for further policy development.

As part of this project, funded through Stage 1 of the SMART Grants Program, WCOG and the IMTC are overseeing a team of consultants led by **Transpo Group** to develop a detailed design and implementation plan for a binational border wait time system that will solve existing system challenges and support additional features including an anti-idling system to reduce greenhouse gas emissions; data feeds to inspection agencies and the Cascade Gateway Border Data Warehouse; real-time traffic operation applications including websites, variable message signs, and alerts; and possible wider-range applications to look at travel patterns. The Transpo team will be engaging these stakeholders regularly throughout the course of this project.

2.2.2 Southbound ATIS

The southbound ATIS is comprised of several components, including inductive loop detectors and associated controller cabinets (known as Vehicle Detection Stations [VDS]), DMS, hybrid DMS, CCTV cameras, Uninterruptible Power Supplies (UPS) for some roadside equipment, and the ATIS server, which is a roadside cabinet located on the northeast corner of the Pacific Weigh Scale near Hwy 15 & 4th Ave in BC. The controller cabinets collect data from the inductive loop detectors and reports it back to the ATIS server via the communications network, which utilizes a combination of fiber optic, wireless, and leased line communications.

The ATIS server processes this data, which includes the roadside traffic data and geographical distances between the loop detectors to estimate queue lengths and discharge rates, as well as booth status data from USCBP, to calculate the estimated border wait times. The booth status data is provided by USCBP via a raw data feed for Privately Owned Vehicle (POV) lanes only, and does not include lanes dedicated to Commercial Motor Vehicles (CMV). However, since this currently involves a manual process for USCBP to provide this data, the algorithm only utilizes this data feed when it is available. The system and associated algorithm, which was originally developed by Arcadis/IBI Group for BCMOTI, is proprietary in nature, so specific details on the software and programming are not known. The border wait times are then transmitted from the ATIS server to the relevant DMS, as well as the ATIS website (<https://www.th.gov.bc.ca/ATIS/index.htm>) for public consumption, though the latter has since been taken offline due to data inaccuracies and unreliability. Figure 2 below shows the network diagram of the existing southbound ATIS.

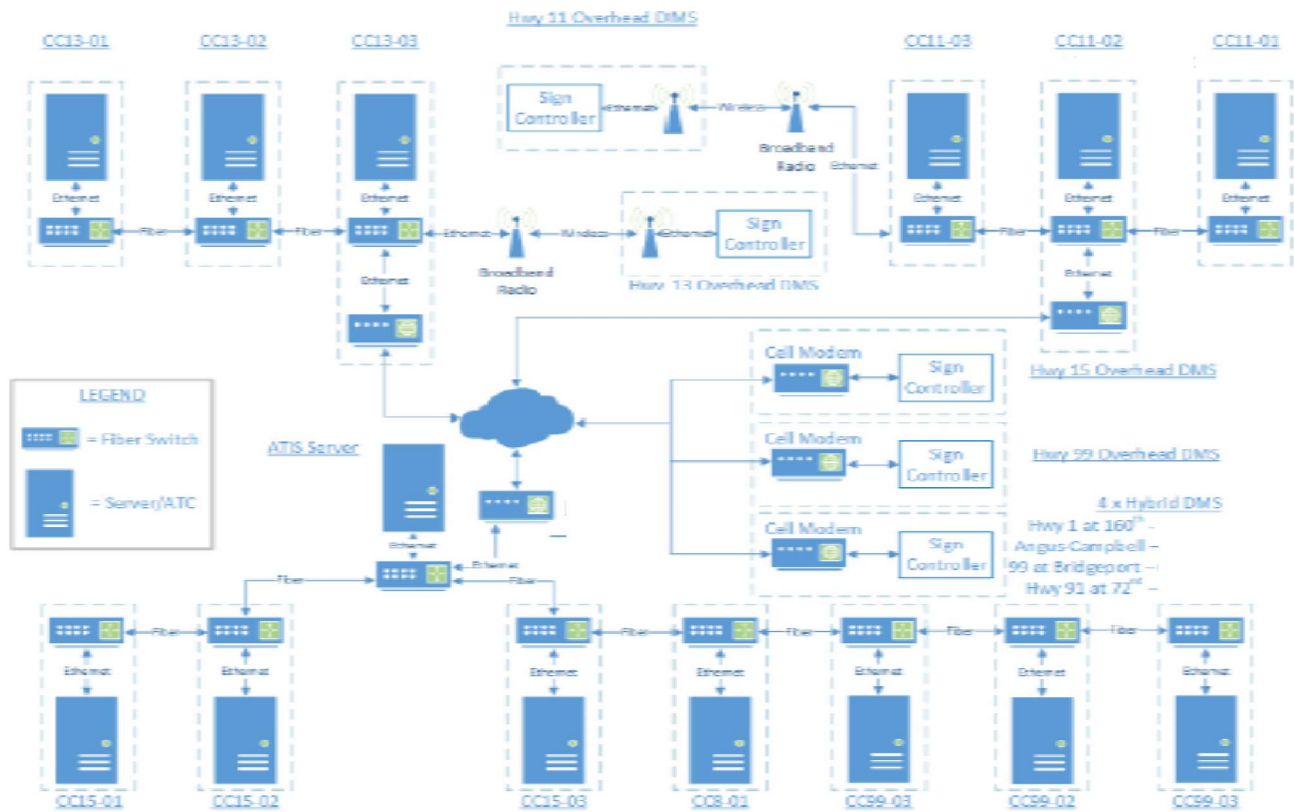

Figure 2. Southbound ATIS Network Diagram

The Peace Arch crossing also features an anti-idling system, which instructs vehicles to turn off their engines when queues extend beyond a certain point along the southbound approach. When a pre-determined queue is exceeded, a traffic signal changes to red to halt traffic. After a certain period of time, or when the queue disperses, the traffic signal changes to green and allows groups of vehicles to proceed toward a staging area near the primary inspection booths.

Figure 3 below is extracted from the southbound ATIS’ private webpage, which shows an overview of the system components and identifies any system faults that have been detected. This includes information on current traffic flows, messages and wait times that are being shown on DMS, and links to images from CCTV camera video feeds (which are pulled from BCMOTI’s File Transfer Protocol (FTP) webpage and also displayed on the DriveBC webpage).

In 2022, an additional enhancement was made to the queueing algorithm. Previously, the algorithm had a maximum queue value for all crossings, but users found that there were becoming more frequent events in which the queue became substantially higher than the pre-configured maximum value. As such, a dynamic maximum queue algorithm was implemented.

The southbound ATIS is operated by Arcadis/IBI Group on behalf of BCMOTI, and maintained by Cobra Electric on behalf of BCMOTI.

Additional details on system components can be found in Section 2.2.5 Existing System Components.

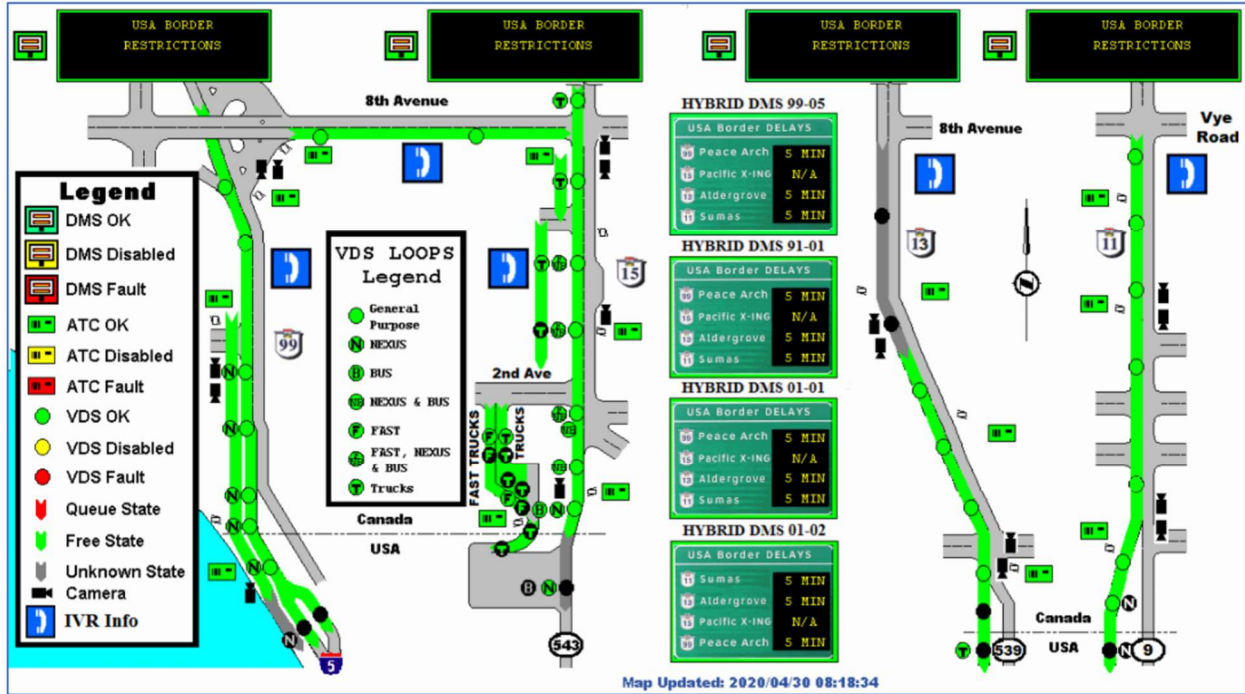

Figure 3. Existing Southbound ATIS Layout

2.2.3 Northbound ATIS

The northbound ATIS is similar to the southbound ATIS, but was developed by, and is currently operated and maintained by WSDOT. The northbound ATIS consists of inductive loop detectors and associated controller cabinets (known as Data Stations), VMS, and CCTV cameras. The controller cabinets collect data from the inductive loop detectors and reports it back to the WSDOT TMC via the communications network, which utilizes a combination of fiber optic and wireless communications. The northbound system also lacks the anti-idling system that is currently present at the southbound Peace Arch/Douglas crossing.

WSDOT is currently in the process of migrating the BWT algorithm from C++ to C# so that the underlying code can become more manageable and accessible. The algorithm, housed on a server at WSDOT's Bellingham facility, is primarily divided into three services, which includes: 1) NG_ES for traffic data collection; 2) NG_TravelTimeEx for queue length calculations; and 3) NG_VMS for VMS messaging. An overview of the data flow is shown in Figure 4 below.

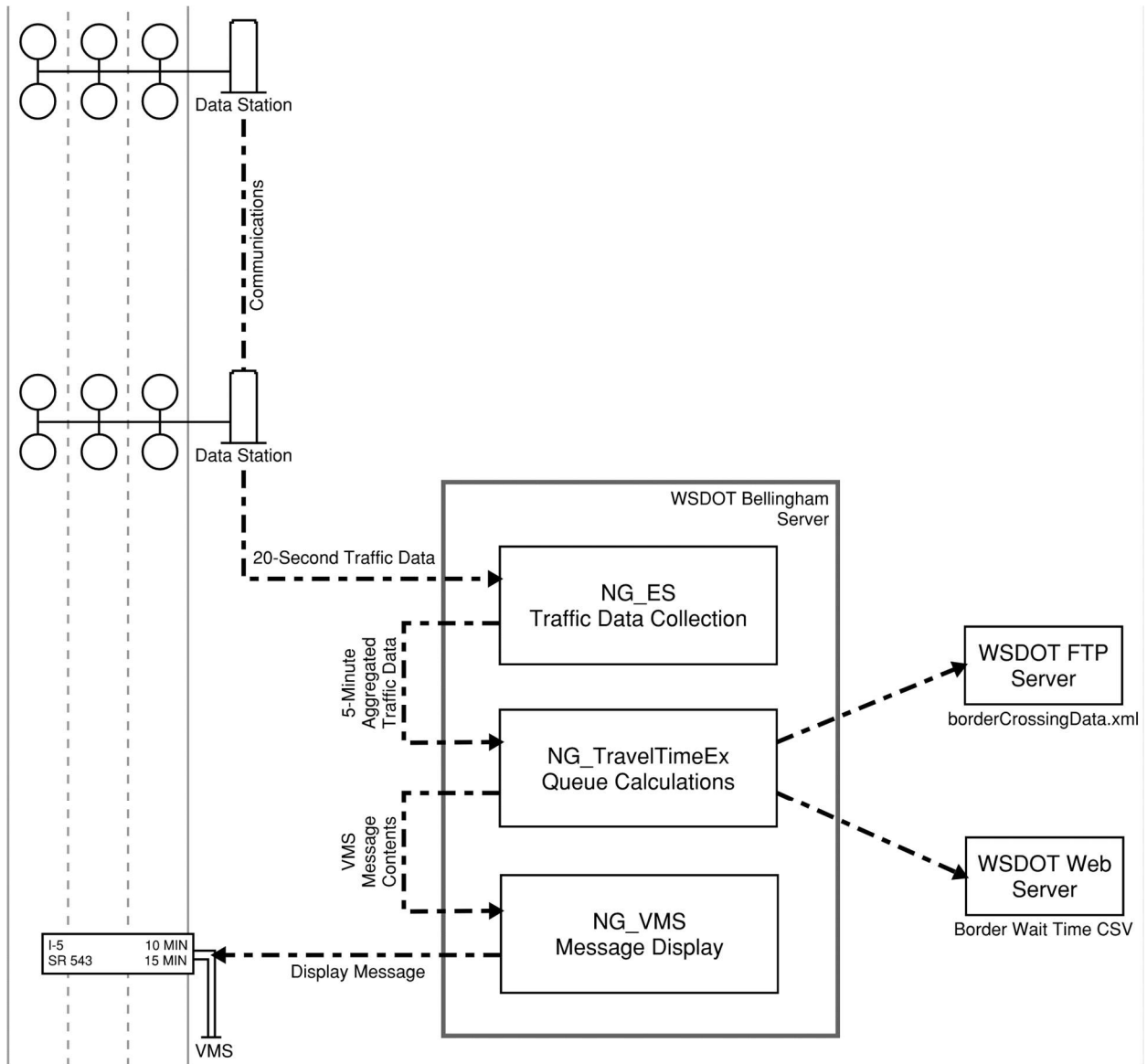

Figure 4. Northbound ATIS Data Flow Diagram

Traffic data is collected using inductive loop detectors in the field, which measure vehicular volumes and occupancy (i.e., the percentage of time that the loop detector is actuated). Note that although the data stations include two loop detectors in each lane to measure vehicle speeds, speed data is not used for the BWT algorithm. The loop detectors are connected to the adjacent roadside data station cabinets, which transmit traffic data back to the NG_ES service every 20 seconds. The NG_ES service then aggregates the traffic data for the data that were received for the previous five minutes into single values each for volume and occupancy and provides the NG_TravelTimeEx service with those two values every five minutes.

The NG_TravelTimeEx service uses the volume and occupancy data to determine the queue lengths and wait times for each POE. After going through a series of checks to validate the traffic data, the service performs the calculation, which includes several checks and parameters. Ultimately, the service rate loop detectors at the primary inspection area and upstream loop detectors, and the associated volume and occupancy data, are used to calculate the queue lengths and the service rates.

The queue length is determined based on the relative locations of the data stations, in conjunction with the volume and occupancy data. For example, if a downstream loop detector has an occupancy that is greater than a pre-configured threshold (15%), then it is considered occupied. The queue length is then calculated based on the known location of the furthest upstream loop detector that is occupied, plus the number (volume) of vehicles counted beyond that point (by another data station that is located further upstream) multiplied by an assumed average vehicle length (25 feet). However, one of the limitations of this approach is that if the queue extends beyond the last loop detector, the system would not be able to determine the back-of-queue and would just report that it is beyond the maximum back-of-queue. Another limitation is related to the assumed average vehicle length, particularly for locations where there is a significant amount of commercial/bus traffic.

To determine the wait time, the service rate loop detectors at the primary inspection area are used to determine a raw service rate. Exception/adjustment factors, which were developed based on WSDOT's observations of field conditions, are then applied to determine a calculated service rate. The queue length is then divided by the calculated service rate to determine the wait time. The service rate loop detectors are critical to the algorithm; if a service rate loop detector fails, the system stops reporting data.

The algorithm also takes into consideration how many lanes are open at each POE. Included in the calculation is each POE's hours of operation (open or closed). The algorithm also infers how many lanes are open at any given time; if the service rate loop detectors count a vehicle in the lane, then the lane is considered open, which factors into the service rate calculation.

Every time the NG_TravelTimeEx service runs, two parallel services also operate to generate the borderCrossingData.xml, which includes data (e.g., inferred lane open/close status, queue length, vehicle volume, occupancy, calculated service rate, etc.) for all four POEs and is posted to the WSDOT File Transfer Protocol (FTP) server for use by the Cascade Gateway Border Data Warehouse, as well as individual CSV files for each POE for each mode (e.g., general purpose, NEXUS, trucks, FAST) with data (e.g., delay/wait time, queue length, raw and calculated service rates, queue lengths, exception/adjustment factors, and number of open lanes) that is posted to the WSDOT Web Service so that wait times can be viewed by the public on the WSDOT travel time website (<https://wsdot.com/travel/real-time/border-crossings> and <https://wsdot.com/Travel/Real-time/Map/>). Note though that while the data includes different lane assignments, these are static in nature; the current algorithm is not capable of automatically adjusting for dynamic lane/booth status changes.

Lastly, the NG_VMS service runs every five minutes to update the wait times that are displayed on VMS located in advance of the POEs.

Additional details on system components can be found in Section 2.2.5 Existing System Components.

2.2.4 Cascade Gateway Border Data Warehouse

The original iteration of the Cascade Gateway Border Data Warehouse, which was launched in 2007 and operated until January 2010, was designed as a border data warehouse accessible through www.CascadeGatewayData.com. This was in response to the recognition of the value of preserving historic wait time data from the WSDOT and BCMOTI systems, which were not previously archived. This online platform served as a repository for all data collected from the BCMOTI and WSDOT ATIS in five-minute increments. The database stored various traffic-related metrics, including traffic volume, delays, arrival rates, and other relevant information categorized by crossing and direction.

Key features of the original system included custom query functions, allowing users to access data by individual loop detector, as well as an email notification system for border wait times exceeding specified thresholds. The backend functionalities utilized FTP protocols based on an interagency XML schema, and the system ran on a UNIX server employing Ruby on Rails technology backed by a PostgreSQL database, with Apache serving the website.

A data collection service polls the data sources for the NB and SB ATIS, aggregates the data, cleans the data, and archives it. Raw data from the SB system is privately accessible to BCMOTI and Arcadis/IBI Group, while raw data from the NB system is publicly available. An API enables the calculated BWT to be posted to DMS/VMS.

The database infrastructure transitioned to a SQL Server 2008 relational database to accommodate the full history of collected data, which continued to be queried by web applications, API users, and the data collection service. Amazon Web Services (AWS) Glacier was utilized to maintain full backups to alleviate the strain on the database. The Cascade Gateway BDW website offered users access to query, reporting, and subscription functions, as well as numerous APIs utilized by various applications, including the DriveBC Historical Border Delays website and the WSDOT mobile app. Administrative access was restricted to two entities: WCOG and Arcadis/IBI Group.

Following the initial phase, a significant upgrade was deemed necessary to maintain the functionality of the data warehouse. The subsequent iteration of the system (BDW 2.0) introduced enhancements to improve data collection and accessibility. The data collection service was responsible for polling configured data feeds to capture detector data, with the database maintaining the relationship between crossings, lanes, and detectors.

To address challenges faced by the previous version (BDW 2.0), an upgrade to BDW 3.0 occurred in 2020, which is the current version in use today. This upgrade included restructuring the warehouse, incorporating US CBP booth status data, enhancing visualization interfaces, and improving backend reporting and maintenance procedures. USCBP booth status data was captured for each vehicle, including information such as the number of passengers, state/province indicated by the license plate, lane number, and traffic mode (e.g., NEXUS, Car, Ready). A five-minute binned version of the booth data feed was employed to enhance query and report performance. CBSA booth status data is not currently available.

In the past, additional data sources were available to the BDW; freight data from private trucking companies were available via an API, and WSDOT weigh-in-motion data was available as well. However, there were issues with these data sources, so the integration was decommissioned.

The current system (BDW 3.0) features an updated Extract-Transform-Load engine (ETL) to improve notifications to system administrators about data source availability and system health. Separate repositories for reporting data and storing data help to optimize performance and support improved querying capabilities.

Hardware and equipment for data collection are owned by partner agencies, with BDW 3.0 hosted on an AWS instance. WCOG oversees system administration and maintenance, coordinating with the development team at Arcadis/IBI Group. Ongoing support is provided through existing infrastructure funded by partner agencies, with WCOG responsible for administering the database and seeking funding for ongoing maintenance post-upgrade. The system architecture of the Cascade Gateway BDW 3.0 is shown below in Figure 5.

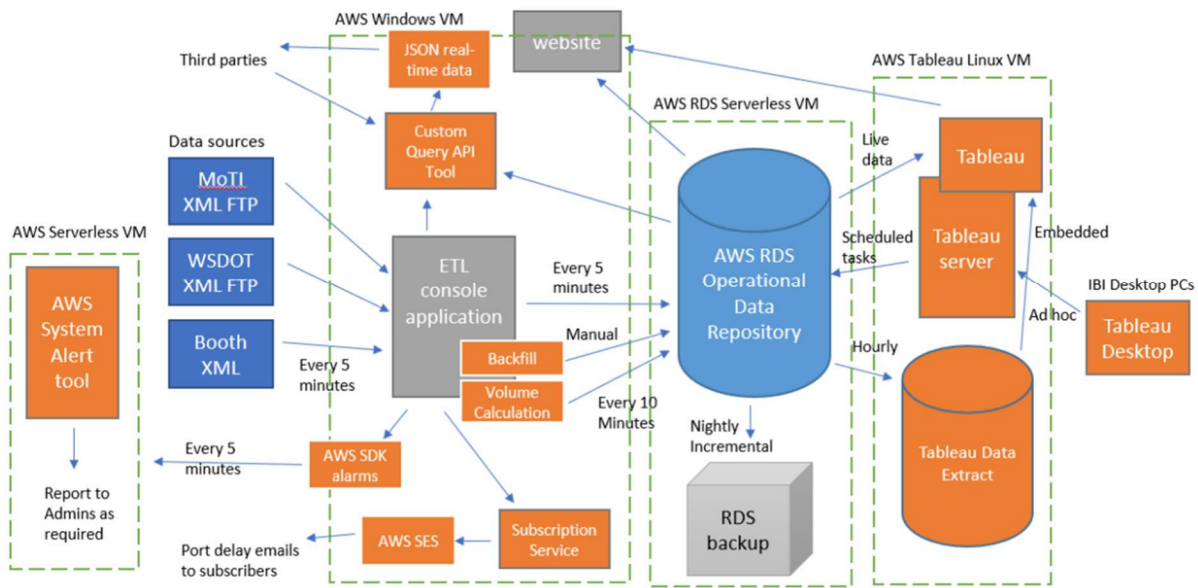

Figure 5. System Architecture of BDW 3.0

The current system is sustained through the collaborative efforts and financial support of partner agencies including WSDOT and BCMOTI. These agencies contribute to the maintenance and upkeep of the infrastructure that underpins the BDW. WCOG is also responsible for administering the database and establishing a maintenance agreement with a suitable entity to ensure its continuous operation. Hosting the archive at AWS falls under the purview of WCOG. This responsibility involves managing the infrastructure required to store and maintain the vast amount of border data collected.

2.2.5 Existing System Components

As discussed in Section 2.2.2 Southbound ATIS and Section 2.2.3 Northbound ATIS, the existing system components consist of:

- Inductive loop detectors
- Roadside controller cabinets (vehicle detector stations/data stations) for data collection
- Anti-idling system (at Peace Arch/Douglas for the southbound direction only)
- Dynamic/variable message signs
- Traffic monitoring cameras/Closed-Circuit Television (CCTV) cameras
- Radio Frequency Identification (RFID) readers (at Pacific Highway only)
- Communications systems
- Electrical service
- Back-office systems/servers
 - Southbound ATIS server near Pacific Highway
 - Northbound ATIS server at WSDOT TMC

Figure 6 and Figure 8 below present an overview of the technologies that are currently deployed at each of the POEs, along with how they are connected. An online version of this map can be found at

<https://www.google.com/maps/d/u/0/edit?mid=1Ok2w2dyaRlLhB7f64rVqehhgGn4gRrQ&usp=sharing>, which is the recommended method for viewing.

Note that this map does not show the locations of individual loop detectors or traffic monitoring cameras; only controller cabinets are shown. For locations of individual loop detectors, please visit the Cascade Gateway Border Data Warehouse website (<https://cascadegatewaydata.com/Detector>). For locations of individual traffic monitoring cameras, please visit the BCMOTI ATIS website (<https://www.th.gov.bc.ca/atis/>) and the WSDOT Travel Center Map website (<https://wsdot.com/Travel/Real-time/Map/>).

The following pages also include photos that were taken during the December 2023 site visits, along with brief descriptions of individual components.

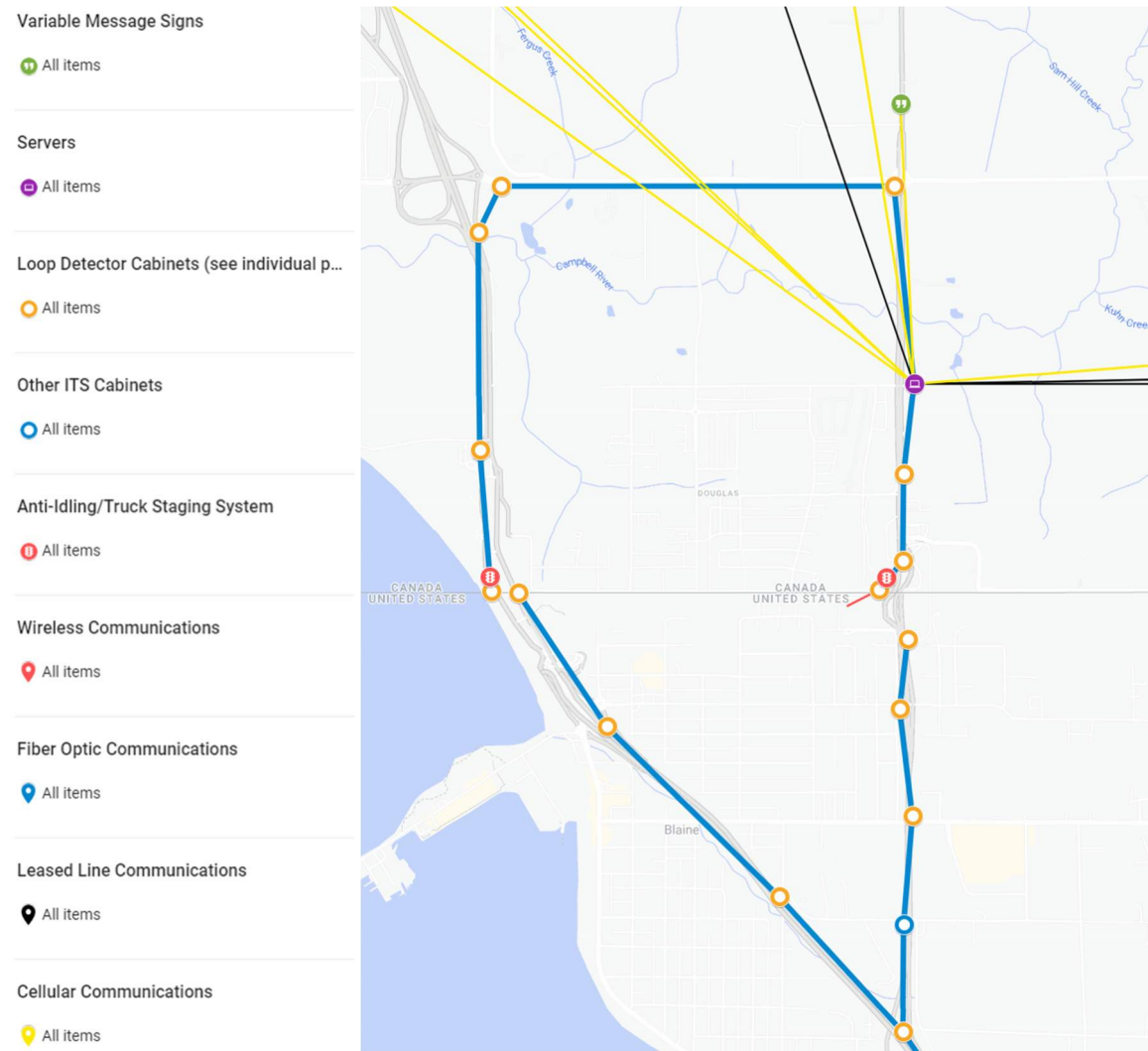

Figure 6. Excerpt from Online Map of Existing System Components at Peace Arch/Douglas and Pacific Highway

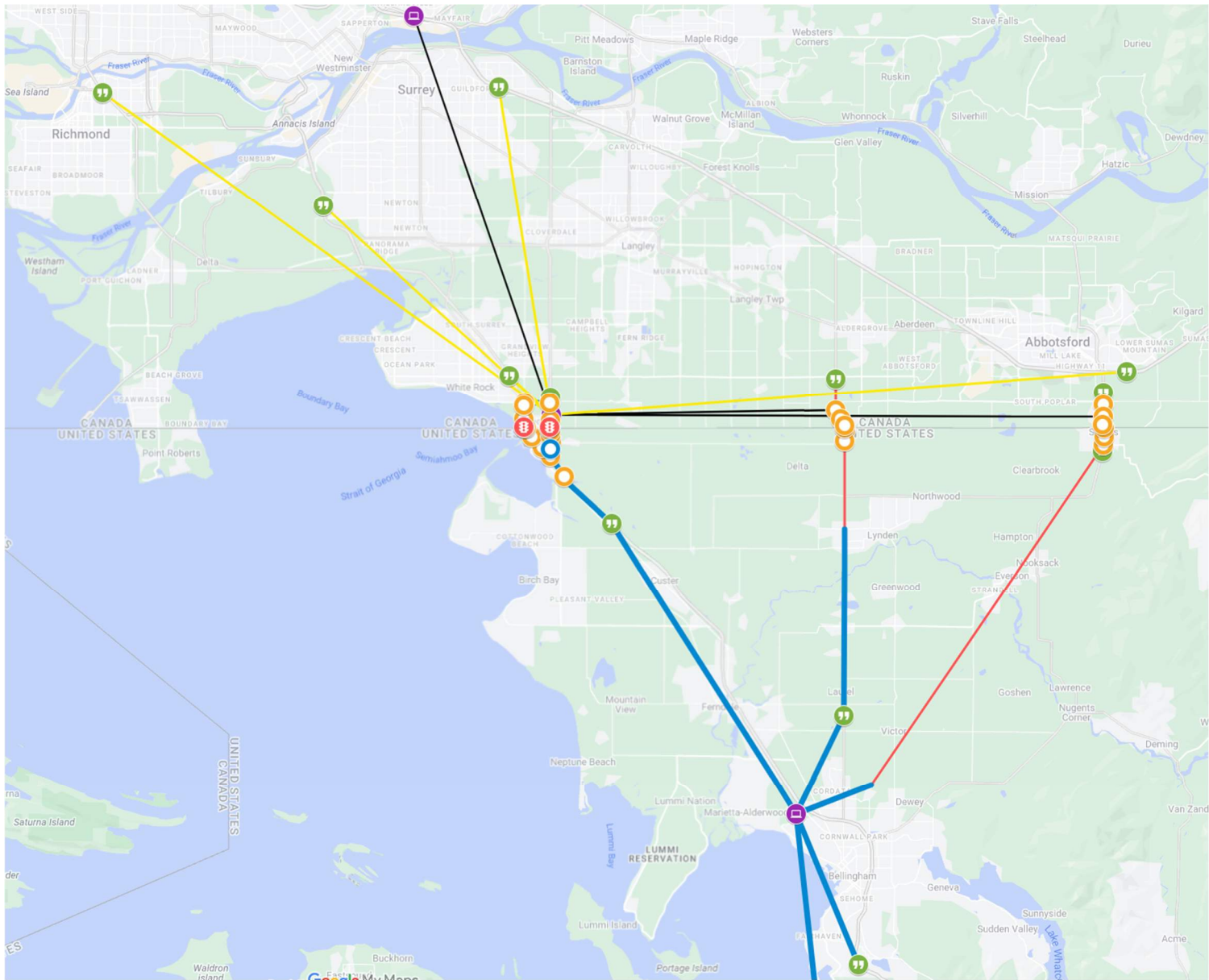

Figure 7. Excerpt from Online Map of Existing System Components - Cascade Gateway Overview

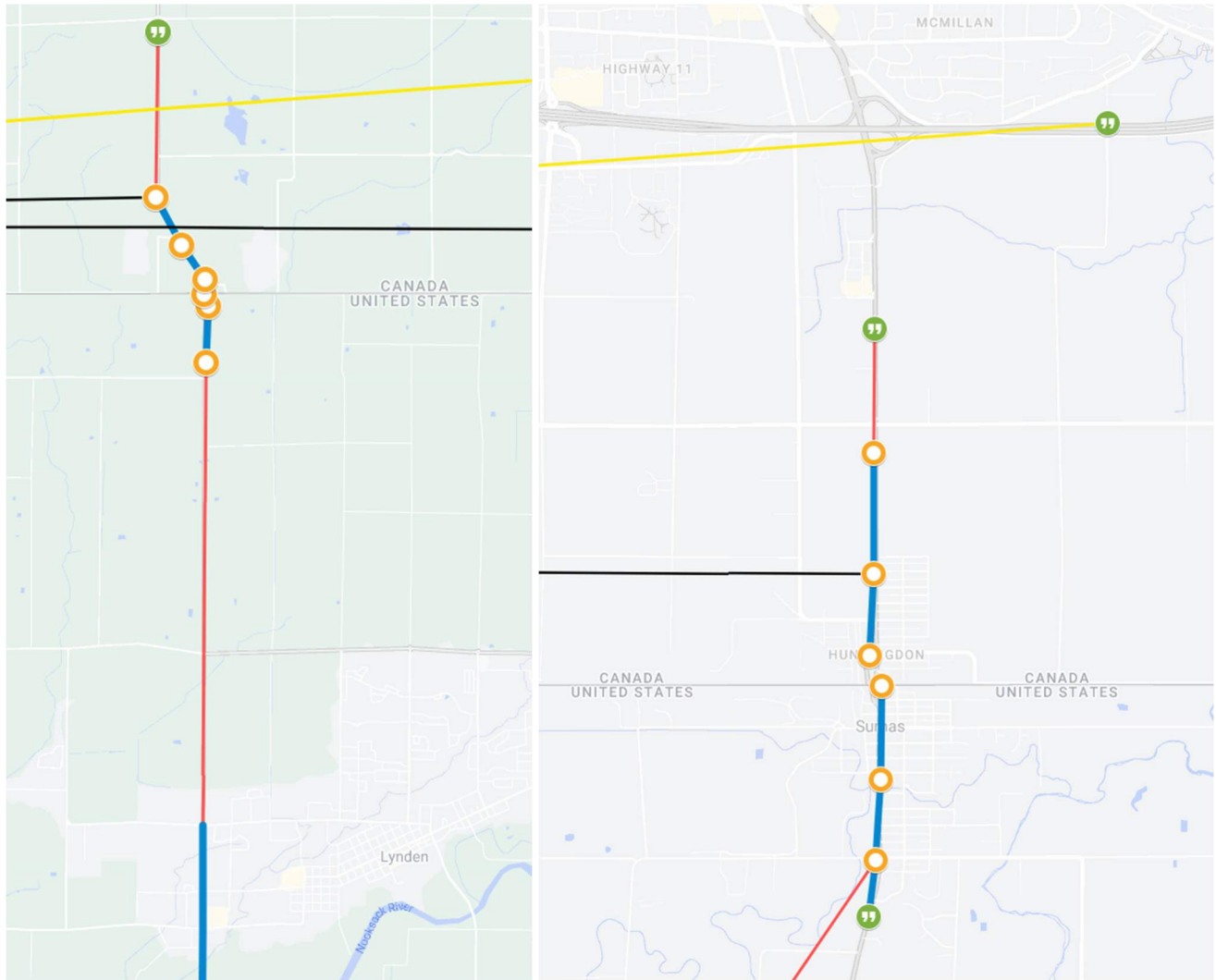

Figure 8. Excerpt from Online Map of Existing System Components at Lynden/Aldergrove and Sumas/Abbotsford-Huntingdon

Inductive Loop Detectors

Inductive loop detectors are installed within the pavement to collect traffic data (i.e., occupancy, volume, and, when combined with a second loop detector, speed) on vehicles traveling over them. The image on the left shows a pair of loop detectors in each lane at Peace Arch/Douglas, which provides vehicle count and speed data as traffic approaches the POE; this is typical for Vehicle Detection Stations and Data Stations on roadways that approach the POE. The image on the right shows a single loop detector (also known as a passage loop detector) just past each Primary Inspection booth, which counts the number of vehicles passing through the POE. See Section 3 for additional details on inductive loop detectors.



Roadside Controller Cabinets

Roadside cabinets house equipment that is needed to collect, process, store, and transmit data for use as part of the BWT calculation and data archival processes. The image on the left shows a BCMOTI Vehicle Detection Station, while the image on the right shows a WSDOT Data Station, both of which are used for inductive loop detector data. These cabinets typically contain loop detector cards, traffic controllers, and communications equipment. For WSDOT, packets of data are sent every 20 seconds from the controller cabinets to the TMC. Data is aggregated every five minutes for archival in the Cascade Gateway Border Data Warehouse, and the VMS are updated every five minutes. See the online version of the [Existing ATIS map](#) for locations of existing cabinets.



Anti-Idling System

The southbound Peace Arch/Douglas approach is equipped with an anti-idling system located approximately 1,000 feet away from the Primary Inspection area, as shown in the upper image. The system consists of a traffic signal that halts traffic for specified time increments at the stop bar when the inductive loop detectors identify that the queue has extended beyond a certain point. Once that occurs, the traffic signal changes to red and vehicles wait typically for 5-20 minutes, or until the queue has dispersed, at which point the traffic signal changes to green. Signage on the traffic signal instructs drivers to turn off their engines when the traffic signal is red. Also shown in this image is a CCTV camera, wireless antenna, and solar panel, though those elements are not directly tied to the anti-idling system. A similar system (truck staging system) also exists at the southbound Pacific Highway approach, consisting of traffic signals, signage, inductive loop detectors, and associated controller cabinet as shown in the bottom images, though it only serves commercial vehicles and sees low compliance from drivers.



Dynamic/Variable Message Signs

Dynamic (BCMOTI's nomenclature) and variable (WSDOT's nomenclature) message signs are electronic signs that can display messages for traveler information. In the context of the ATIS, these signs are used to display the current estimated wait times at nearby border crossings, or to indicate the operating hours for the crossing or for specific lane types. The image on the left shows a shoulder/post-mounted VMS from the Sumas/Abbotsford-Huntingdon POE on the U.S. side, while the image on the right shows the VMS equipment that is housed in an adjacent controller cabinet. DMS/VMS are currently installed well in advance of all four POEs, typically prior to decision points. See the online version of the [Existing ATIS map](#) for locations of existing DMS/VMS.



Traffic Monitoring Cameras

Traffic monitoring cameras, typically ones with pan-tilt-zoom capabilities, are used for traffic monitoring purposes. Both BCMOTI and WSDOT post still images from these cameras on their traveler information websites so that travelers can get a visual sense of how far back the queue currently extends at the border. The images below are from the Sumas/Abbotsford-Huntingdon POE on the U.S. side; the image on the left shows a camera mounted on a luminaire arm, while the image in the middle shows a camera mounted on a standard WSDOT camera pole (behind a weather station tower, which is unrelated to the ATIS), while the image on the right shows a controller cabinet containing both data station (inductive loop detector) and camera equipment. Traffic monitoring cameras are installed extensively throughout BC and WA.



RFID Readers

RFID readers are typically installed overhead at two or more locations to collect data from truck transponders and/or toll tags, to determine the time it took for a vehicle to travel the distance between two readers. The image below shows RFID readers installed on a sign bridge near the Pacific Highway crossing on the U.S. side; RFID readers were not found to be present at any of the other POEs. However, it is unclear as to whether these readers are still in operation; WSDOT ITS has noted that these are not owned or operated by them. See Section 3 for additional details on RFID readers.



Communications Systems

Network communications is a critical component of the ATIS. It allows footage from traffic monitoring cameras to be viewed, and more importantly, serves as the means to transmit the traffic data that is collected at the roadside to server(s) where the data is processed and calculated into estimated border wait times. Various methods of communications are used for both the northbound and southbound ATIS, but generally includes fiber optic, wireless, and leased line communications systems. Based on discussions with WSDOT and BCMOTI, fiber optic communications has been working well, but wireless communications has been unreliable and have resulted in frequent data drops, which may be due to the age of the equipment. Additionally, the wireless communications technologies used by WSDOT at the Lynden and Sumas POEs are vastly different from one another. At Lynden, the existing NB ATIS is connected locally via fiber optic communications. However, there is a small fiber optic communications gap to the south, so WSDOT's uses a Ubiquiti point-to-point wireless system that connects the NB ATIS equipment to the nearby traffic signal at SR 539 & Badger Road (approximately two miles away to the south), which is then connected back to the WSDOT TMC via fiber optic communications. At Sumas, the existing NB ATIS is also connected locally via fiber optic communications. However, there is no other nearby fiber optic communications, so WSDOT uses a Solectek point-to-point wireless system that connects the NB ATIS equipment to WSDOT's existing network at King Mountain (approximately 16 miles away). The image on the left shows wireless communications in use by BCMOTI at Pacific Highway, while the image in the middle shows wireless communications in use by WSDOT at Sumas/Abbotsford-Huntingdon, while the image on the right shows fiber optic communications utilized by WSDOT.

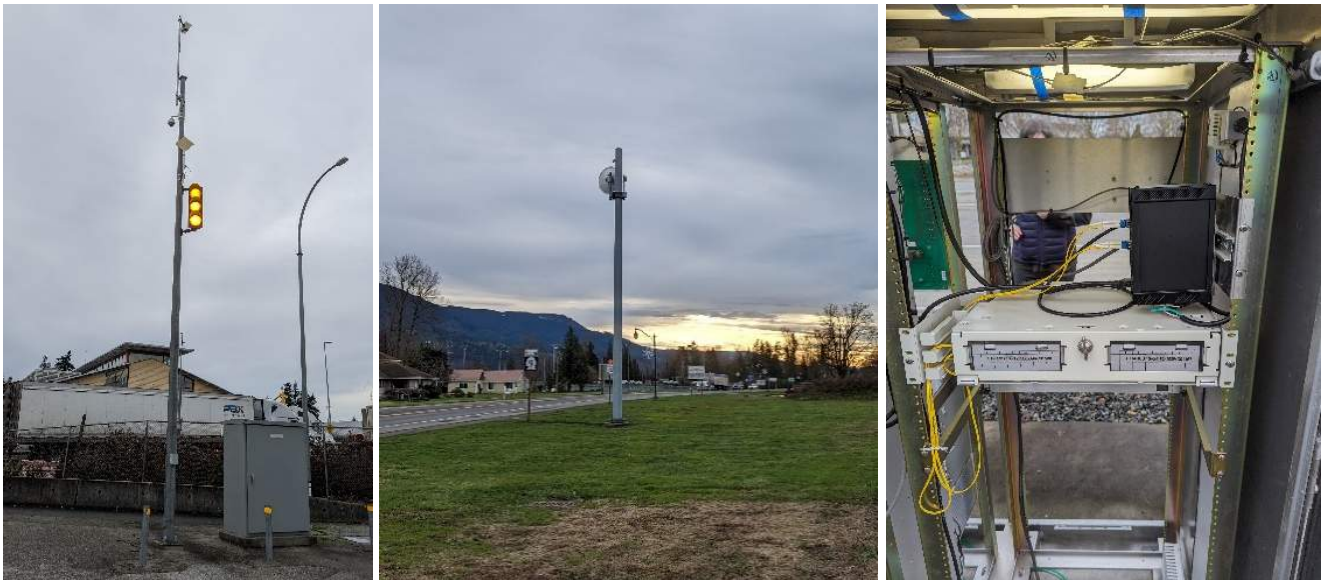

Electrical Service

Traffic signal and ITS cabinets typically operate on 120V power. A metered electrical service cabinet (pictured in the middle, which is from Pacific Highway on the U.S. side) is typically required to convert the utility power source to 120V, which is the voltage typically needed to power the controller cabinet and the components that it is connected to, which typically draws utility power from a nearby power source (pictured on the left, which is from Lynden/Aldergrove on the Canadian side). Battery backup/Uninterruptible Power Supply (UPS) systems are also beneficial in keeping systems running in the event of a power outage (typically 24 hours or less for WSDOT UPS); the image on the right is from Pacific Highway on the Canadian side, though UPS are not in use consistently.



Back-Office Systems

The back-office systems refer to servers and other IT-related infrastructure that are critical to the operation of the ATIS. In particular, the southbound system relies on the ATIS server, which is located at the roadside at the northeast corner of the Pacific Weigh Scale near Hwy 15 & 4th Avenue in BC. The images below show the front and rear views of this cabinet, which houses a computer that handles the border wait time calculations, and communications equipment for transmitting data. See Section 2.2.2 Southbound ATIS and Section 2.2.3 Northbound ATIS for additional details.



Systems Unrelated to ATIS

Near the POEs, there are also other systems in use, but they are unrelated to the ATIS. This includes DMS/VMS to convey booth assignments, and sensors like monitoring cameras, license plate recognition cameras, and radiation sensors for USCBP/CBSA operations.



2.2.6 Existing System Challenges and User Needs

To effectively evaluate future tasks and propose necessary adjustments to address existing gaps, it is important to acknowledge and thoroughly study the system’s user requirements and understand the challenges they face. This involves considering project goals, reviewing documentation from IMTC organizations, and analyzing available reports and studies that describe the current system mechanisms. Furthermore, direct input from the actual users who interact with and operate the system is invaluable in identifying these gaps.

To facilitate this process, a kick-off meeting was convened on December 12, 2023 at the Canada Border Services Agency's Douglas POE, involving key stakeholders with representatives from WCOG, USCBP, CBSA, WSDOT, BCMOTI, and the project consultant team. Within this meeting, breakout sessions were conducted with various stakeholder groups to obtain input tailored to their unique perspectives and experiences with the system. The objectives of these breakout sessions were twofold:

- 1) To inquire about the current methods of collecting, processing, and disseminating border wait times for both private vehicles and commercial motor vehicles; and
- 2) To identify deficiencies and challenges encountered by stakeholder agencies within the existing system.

The insights gathered from the kick-off meeting, breakout sessions, and site visits have served as a preliminary stakeholder engagement activity for the project team, allowing for some initial issues and user needs to be identified. These initial findings are summarized in the sections below. Note though that additional meetings will be held with stakeholders throughout the course of the project, which will help further elicit user needs, review the system concept, and gather additional thoughts and input from stakeholders.

Issues and Challenges

Table 1 below presents a summary of the issues and challenges that were voiced during the December 2023 meetings, which have been grouped into logical classifications.

Table 1. Existing Issues and Challenges with Current ATIS

Classification	Issue/Challenge
System	Reliability issues with the existing wireless communications system caused data updates to be delayed by 15 minutes at Ports of Entry (POEs) such as Sumas and Lynden.
	Loop detector maintenance is an ongoing issue requiring significant effort and labor.
	Lack of information on upstream traffic data hampers wait time estimation.
	The system’s data updating frequency needs to be lowered as this affects the accuracy and utility of the system
	Slow speed and lane changes within the loop detectors result in inaccurate data records.
Algorithm	Inaccurate wait time estimates, particularly at Lynden POE where issues with data transmission reliability are present. The inaccuracy in wait time estimates is especially significant on the BC side which has stopped the wait time being shown online.
	Lack of transparency and documentation on the border wait time algorithm for the SB ATIS, which was developed years ago and is proprietary, hindering understanding and optimization of the algorithm.

Classification	Issue/Challenge
	The VMS displays the wait time solely, rather than reflecting the travel time and wait time for traffic management issues.
	The algorithm lacks scenario analysis to accommodate factors like heightened traffic, increased demand, and special events.
Operations	Lack of information regarding what mode is being processed through each lane.
	Pedestrian lanes prioritized over motorized vehicles, causing additional delays in vehicle processing as the same officer attends both pedestrian and motorized vehicle queues.
	Security staff lack real-time information on upcoming traffic demand, hindering the effective allocation of inspector officers at booths.
	Security staff need to adjust operations and staffing to ensure lower waiting times for NEXUS users.
	Not all lanes are interchangeable for the NB POEs, like at Douglas where the NEXUS lane is physically separated, leading to extra delays when one lane has shorter queues.
	Traffic management center staff need the ability to disable wait time information from displaying (e.g., on websites, apps, VMS, etc.) when information is inaccurate, or the border is closed.
	Several of the POEs will undergo redevelopment and/or expansion, which will alter traffic patterns and operations. Flexible technologies that can easily be re-located, re-installed, or simply re-configured would be preferred. Information will be needed to ensure that the system's physical design and algorithm accommodate these changes.
Roadway Design	Uneven lane branching at the SB Pacific Highway POE leads to delays, particularly affecting NEXUS and Ready lanes due to unaccounted traffic from lane merging upstream.
	Inadequate turning radius for commercial vehicles at the southbound Pacific Highway lanes hinders lane utilization, leading to higher-than-reported border wait times.
	Truck staging area design issue in SB POE; insufficient space dedicated to stage trucks causing delays in both approaches at Pacific Highway.
Equipment	Ageing equipment and inaccurate data contribute to delays at the border.
Other	Routing applications and tools not accounting for border wait times, defaulting to Peace Arch border crossing irrespective of wait times.

User Needs

Table 2 below presents a summary of the user needs that were identified during the December 2023 meetings, which have been grouped into logical classifications. These user needs are currently in the early stages of development and will need to be prioritized in alignment with project requirements and objectives. The prioritization process will occur as part of the development of the Concept of Operations.

Table 2. User Needs for Future ABIS

Functional Class	User Need	Priority	Traceability to Issues/Challenges Categories
System Features	The ABIS needs to consider and be compatible with the existing anti-idling system at Peace Arch/Douglas (SB).		SYSTEM
	The ABIS needs provide a new anti-idling system at Peace Arch/Douglas (NB).		SYSTEM
	The ABIS needs to consider and be compatible with upcoming initiatives, including but not limited to: <ul style="list-style-type: none"> • CBSA Assessment and Revenue Management (CARM) • U.S. CBP Automated Commercial Environment (ACE) • NEXUS eGate • Planned/on-going construction projects (e.g., reconstruction and expansions at Pacific Highway, Lynden/Aldergrove, and Sumas/Abbotsford-Huntingdon, George Massey Tunnel replacement project, Highway 13 expansion, Abbotsford overpass construction, etc.). 		
	The ABIS needs to consider privacy as it relates to laws and regulations for both the U.S. and Canada.		DATA SHARING
	The ABIS needs to consider data security and cybersecurity best practices. For example, servers that calculate the BWTs should not be located at the roadside.		EQUIPMENT
	The ABIS needs to utilize open standards and algorithms.		ALGORITHM
	The ABIS needs to be updated on a regular basis. This may include system/server updates, security updates, algorithm updates, and data transmission networks/methods.		SYSTEM

Functional Class	User Need	Priority	Traceability to Issues/Challenges Categories
	The ABIS needs to be scalable to accommodate future data needs (e.g., additional lanes, lane types, POEs, data sources, etc.)		SYSTEM
	The ABIS needs to serve as a test case for other agencies, such that a similar system can potentially be deployed at other U.S. – Canada and U.S. – Mexico border crossings.		OTHER
	The ABIS needs to be resilient and reliable (e.g., minimal down-time).		SYSTEM
System Algorithm and Data Collection	The ABIS needs to automatically adjust to changing inspection lane types (e.g., open vs closed, NEXUS vs general purpose vs FAST vs bus vs commercial vs pedestrian, etc.)		ALGORITHM
	<p>The ABIS needs to accurately measure BWTs for each lane and lane type at each POE in real-time.</p> <ul style="list-style-type: none"> • At Pacific Highway NB and SB going to/from BC 15 and SR 543, the physical geometry results in uneven lane bifurcation (e.g., two lanes becoming four or six) where a bottleneck forms, since drivers might not be aware of additional lanes becoming available near the primary inspection area. • At Pacific Highway SB for commercial vehicles, the physical geometry is insufficient for trucks to make wide turns as they approach the inspection area., resulting in some lanes being underutilized and delays being more than what is reported. 		INFRASTRUCTURE

Functional Class	User Need	Priority	Traceability to Issues/Challenges Categories
	The ABIS needs to consider both real-time and historical traffic data in its calculation of travel time and BWT.		ALGORITHM
	The ABIS needs to measure emissions in real-time at each POE.	Medium	SYSTEM
	The ABIS needs to estimate emissions in real-time at each POE.	High	SYSTEM
	The ABIS needs to consider and not preclude the use of crowdsourced data (e.g., location-based services data), either in lieu of or to supplement the use of field equipment.		ALGORITHM
	The ABIS needs to consider the use of freight data (e.g., data feeds from trucking companies, data collected from RFID readers/truck transponders, etc.).		SYSTEM
	The ABIS needs to measure how traffic diverts to other POEs as they approach the border. This may involve a report that documents the quantity and type (e.g., general purpose, freight, etc.) of vehicles traveling in certain directions along certain corridors, and the percentage of vehicles that head towards the various POEs.		SYSTEM
	The ABIS needs to be suitable for use in border crossing environments, such as being capable of measuring slow-moving vehicles that are changing lanes.		SYSTEM
Traveler Information	The ABIS needs the ability to disseminate BWTs for each lane type at each POE for a vehicle at the current back-of-queue.		SYSTEM
	The ABIS needs the ability to disseminate BWTs for each lane type at each POE for a vehicle at the VMS displaying the BWT message. The BWT displayed needs to		SYSTEM

Functional Class	User Need	Priority	Traceability to Issues/Challenges Categories
	include the time needed for the vehicle to travel to the back-of-queue, as well as any additional wait time associated with the formation of longer queues.		
	The ABIS needs the ability to identify alternative POEs that drivers should divert to, based on factors such as distance, BWT (inclusive of travel time to forecasted back-of-queue), greenhouse gas emissions, etc.		OTHER
	The traveler information system needs the ability to automatically divert traffic to other POEs.		
	The traveler information system needs to provide more clear and detailed VMS messaging.		
Data Transmission, Storage, and Archival	The ABIS needs to reliably disseminate BWTs to various sources in a timely manner, including existing traveler information systems (e.g., Variable Message Signs [VMS], traveler information websites, mobile apps, etc.) and the BDW. BWTs need to be disseminated to traveler information systems at a minimum frequency of every minute.		SYSTEM
	The ABIS needs to include an Application Programming Interface (API) for others to access the data. Real-time data feeds will need to be provided to, at a minimum: WSDOT, BCMOTI, U.S. CBP, CBSA, WCOG (Cascade Gateway Border Data Warehouse [BDW]).		DATA SHARING
	The ABIS needs to archive BWT data indefinitely in the BDW.		DATA SHARING

Functional Class	User Need	Priority	Traceability to Issues/Challenges Categories
	<p>The ABIS needs to collect and archive the following data, at a minimum:</p> <ul style="list-style-type: none"> • Measured BWT for each lane and lane type at each POE. • Vehicle volumes for each lane and lane type at each POE. • Vehicle speeds for each lane and lane type at each POE. • Queue length/location of back-of-queue at each POE. 		DATA SHARING
	<p>The ABIS needs to collect and archive the following data, at a minimum:</p> <ul style="list-style-type: none"> • Vehicle classifications for each lane and lane type at each POE. 		DATA SHARING
	<p>The ABIS needs to be compatible with the existing BDW.</p>		DATA SHARING
	<p>The ABIS needs to, at a minimum, utilize the existing data fields and formats that are currently in use by the existing BDW.</p>		DATA SHARING
	<p>Wireless communication at Lynden (NB) is expected to remain for the foreseeable future. A more reliable wireless communications system is needed.</p>		DATA SHARING
System Operation and Maintenance	<p>Customs officers need to know the real-time traffic demand at and approaching each Port Of Entry (POE), in order to be able to adequately staff the inspection booths at any given time.</p>		ALGORITHM
	<p>Customs officers need the ability to change inspection lane assignments (e.g., NEXUS vs general purpose).</p>		
	<p>Customs officers need to have easy and reliable access to accurate wait times, issues, and alerts. Currently, there are various sources of information (e.g., WSDOT's Border Wait Time [BWT])</p>		

Functional Class	User Need	Priority	Traceability to Issues/Challenges Categories
	website, WSDOT’s Travel Center Map website, BCMOTI’s DriveBC.ca website, etc.).		
	The data that customs officers primarily need access to on a day-to-day basis includes BWTs for each lane type at each POE.		
	<p>Customs officers need the ability to perform “what-if” scenario analysis to predict how BWTs may change within the near future (e.g., within the next few minutes or hours).</p> <ul style="list-style-type: none"> • This needs to consider both real-time upstream traffic data, as well as manually-entered traffic volumes (to simulate surges in traffic, special events, etc.). A range of BWTs (e.g., 15–20 minutes) may be provided. 		ALGORITHM
	<p>Customs officers need the ability to perform “what-if” scenario analysis to predict how BWTs may change for any given time, date, or month (e.g., 4pm on July 1st).</p> <ul style="list-style-type: none"> • This needs to consider historical traffic data, as well as manually-entered traffic volumes (to simulate surges in traffic, special events, etc.). A range of BWTs (e.g., 60–90 minutes) may be provided. 		ALGORITHM
	<p>The ABIS needs the ability to automatically alert/notify users of various conditions, including but not limited to:</p> <ul style="list-style-type: none"> • Suspected inaccuracies in the data. • BWTs, volumes, and/or speeds exceeding configurable thresholds. 		EQUIPMENT

Functional Class	User Need	Priority	Traceability to Issues/Challenges Categories
	<p>The ABIS needs to be easily maintainable by agency staff.</p> <ul style="list-style-type: none"> • Equipment located within the U.S. will be maintained by WSDOT. • Equipment located within Canada will be maintained by a contractor on behalf of BCMOTI. 		EQUIPMENT
	<p>The ABIS should include configurable dashboards to aid in operations, monitoring, and decision-making.</p>		SYSTEM
	<p>The ABIS’s field equipment needs to be adaptable to changing conditions at the POEs, such as changing lane types and geometry, maintenance activities (e.g., paving), and physical construction (e.g., planned reconstruction and expansions at Pacific Highway, Lynden/Aldergrove, and Sumas/Abbotsford-Huntingdon).</p>		EQUIPMENT
	<p>Staff need to be trained adequately in the operations and maintenance of the ABIS.</p>		EQUIPMENT

2.3 Planned Projects

Within the next few years, several of the POEs and the adjacent roadways will be undergoing significant development. With the deployment of the ABIS (pending available project funding anticipated through Stage 2 of the SMART Grants Program) anticipated around the same time, it will be important to consider the physical changes that will be coming to the project area to ensure that the technologies being deployed do not significantly conflict with other proposed improvements, and vice versa. Below is a summary of the planned U.S. and Canadian projects that the project team is aware of:

- U.S. Projects
 - **Pacific Highway POE:** “The expansion project will add four new POV inspection lanes, expanding capacity to ten lanes total. The project also expands the secondary inspection area to provide six enlarged bays for vehicle enforcement inspections, 24 secondary main building referral parking spots, and six enlarged bays for secondary inspection enforcement. All inspection areas will include extended overhead canopies, replaced pavement, and upgraded lighting.”
 - **Lynden/Aldergrove POE:** “The expansion project will expand and separate personal vehicle traffic and commercial screening operations, possibly allowing for a 24-hour, full-service port

operations. When completed, the port at Lynden will feature five personal vehicle lanes and four commercial processing lanes.”

- **Sumas/Abbotsford-Huntingdon POE:** This project will “expand and modernize personal vehicle and commercial screening operations. Commercial inspection lanes will increase from two to four, and personal vehicle lanes will increase from five to six. Main building operations will be fully modernized and a dedicated pedestrian corridor will be constructed.”
- **Canadian Projects**
 - **Pacific Highway POE:** As part of the CBSA’s Land Border Crossing Project, the northbound POE will be completely reconstructed. Construction is expected to begin in 2025 and be completed in 2026.
 - **George Massey Tunnel Redevelopment:** The Highway 99 Tunnel Program aims to replace the aging George Massey Tunnel with a toll-free, eight-lane immersed tube tunnel. This program encompasses improvements for motorists, transit, and active transportation users along the Richmond to Delta corridor.
 - **Highway 13 (Lynden/Aldergrove POE) Expansion:** The ongoing expansion of Highway 13, which will include NEXUS lanes, is almost complete. This project modifies roadway geometry, so roadside cabinets/equipment and system algorithms will be updated.
 - **Vye Road Overpass and Highway 11 Widening Project:** This project, which was recently completed, involved widening Highway 11 to extend the NEXUS lane, along with constructing a two-lane overpass on Vye Road. This project modified roadway geometry, so roadside cabinets/equipment and system algorithms were updated.
 - **CBSA Assessment and Revenue Management (CARM) Digital Initiative:** This initiative will introduce a new system for assessing and collecting duties and taxes on commercial goods imported into Canada, akin to the U.S. CBP’s Automated Commercial Environment (ACE).
 - **CBSA Travel Monitoring System:** CBSA is implementing a travel monitoring system focused on NEXUS lanes, utilizing eGates to select commercial motor vehicles for inspection, employing electronic (chip) cards to streamline processes, and integrating CARM in May 2024 (note – this system tracks cargo but does not include wait times).

3. EXISTING MEASUREMENT TECHNOLOGY REVIEW

3.1 Introduction

Section 3 embarks on a detailed exploration of existing Border Wait Time (BWT) measurement technologies at the U.S.-Canada and U.S.-Mexico borders, aiming to inform the development of the ABIS with existing insights and technological innovations. This critical analysis not only underpins the ABIS design with a robust foundation but also seeks to elevate cross-border traffic management through strategic improvements and technological integration. Beyond merely cataloging current technologies, this task explores their practical application, emphasizing the need for dynamic, hybrid systems that blend traditional data collection with advanced predictive analytics to deliver accurate, real-time traveler information. Additionally, the adaptability of these technologies amidst infrastructural changes underscores the importance of flexible, scalable solutions in maintaining operational continuity and measurement accuracy. Through this comprehensive review, the chapter sets the stage for the Concept Development task to provide a holistic view of the technological landscape, operational challenges, and future directions for efficient, responsive border crossings.

3.2 Border Wait Time Measurement System Definitions

The objective of this section is to define key concepts that are used throughout the rest of this chapter to describe BWT technologies and systems. First are the distinct concepts of border wait times and border crossing times, followed by the approaches to measuring BWT.

3.2.1 Wait Times and Crossing Times

The concepts of wait times and crossing times have been used in literature for over ten years. The definitions that are most commonly used have been documented by the Texas A&M Transportation Institute (TTI) in the context of the development of the U.S.-Mexico Border Wait Time Measurement System. These definitions have been adapted to the context of the U.S.-Canada border in the paragraphs below.^{1 2}

Wait Time

In the context of the southern border, wait time for vehicles traveling northbound is defined as “the time it takes for a vehicle to reach the U.S. Customs and Border Protection’s (CBP) Primary Inspection booth after arriving at the end of the queue.” For vehicles traveling southbound, wait time would be the time it takes for a vehicle to reach the Mexican Customs (Agencia Nacional de Aduanas de Mexico, ANAM) primary inspection booth after arriving at the end of the queue.

Similarly, in the context of the ABIS, wait time for vehicles traveling northbound would be defined as the time it takes for a vehicle to reach the CBSA’s Primary Inspection booth after arriving at the end of the queue.

¹ Texas A&M Transportation Institute. *Border Crossing Information System*. <https://bcis.tti.tamu.edu/Commer/Help>. Consulted February 6, 2024.

² San Diego Association of Governments. *San Diego, CA. 2017. Border Wait Time Technologies and Information Systems White Paper*. <https://www.sandag.org/-/media/SANDAG/Documents/PDF/projects-and-programs/borders-and-interregional-collaboration/binational/economic-and-air-quality-impacts-of-delays-at-the-border-2017-10-31.pdf>. Consulted February 6, 2024.

On the other hand, for vehicles traveling southbound, wait time would be defined as “the time it takes for a vehicle to reach the U.S. CBP Primary Inspection booth after arriving at the end of the queue.”

Crossing Time

In the context of the southern border, crossing time for vehicles traveling northbound is defined as “the time it takes for a vehicle to exit the border crossing process after it joins the queue before CBP Primary Inspection booth. Crossing time has the same beginning point in the flow as wait time, but its terminus is located at the end of federal and state inspection compounds.” For vehicles traveling southbound, crossing time is defined as the time it takes for a vehicle to exit the border crossing process after it joins the queue before ANAM’s Primary Inspection booth. Southbound crossing time has the same beginning point in the flow as wait time, but its terminus is located at the end of the Mexican inspection compound.

In the context of the ABIS, crossing time for vehicles traveling northbound would be defined as the time it takes for a vehicle to exit the border crossing process after it joins the queue before the CBSA’s Primary Inspection booth. Northbound crossing time has the same beginning point in the flow as wait time, but its terminus is located at the end of the Canadian inspection compound. On the other hand, for vehicles traveling southbound, crossing time would be defined as “the time it takes for a vehicle to exit the border crossing process after it joins the queue before CBP Primary Inspection booth. Crossing time has the same beginning point in the flow as wait time, but its terminus is located at the end of federal and state inspection compounds.”

3.2.2 Approaches to Measuring BWT

Understanding the approaches most commonly used to measure BWT is key in understanding how technology choices impact the quality, effectiveness, and versatility of a BWT measurement system. The FHWA and Transport Canada first documented in 2008 three main approaches to measuring BWTs.³ These approaches remain relevant today, and have more recently been complemented in additional detail in a study commissioned by the San Diego Association of Governments (SANDAG).²

1. **Estimation via Queue Length:** This technique employs advanced technology and human involvement to monitor the rates of vehicle arrivals and departures, thereby providing an estimate of the queue's size. The estimate is typically derived from the queue's length and an average approximation of vehicle density. The data is processed through a sophisticated algorithm that predicts the time required for the next vehicle to traverse the queue and reach the Primary Inspection booth.
 - Human-involved methods include visual observations, cameras, driver surveys, and time stamp card/toll receipts.
 - Automated methods include inductive loop detectors, ranging radar detectors, and video image processing.

These methods collectively contribute to the accuracy and reliability of the queue length estimation. This method is particularly effective for providing real-time traveler information and once recorded, the data becomes a valuable resource for performance monitoring and further analysis.

² SANDAG. 2017. *Border Wait Time Technologies and Information Systems White Paper*.

³ Sabean, J. and Jones, C. 2008. *Inventory of Current Programs for Measuring Wait Times at Land Border Crossings*. Transport Canada and Federal Highway Administration.

<https://citeseerx.ist.psu.edu/document?repid=rep1&type=pdf&doi=a7d39309dbeb991b0c97263e6ff22d4e295cda70>. Consulted February 6, 2024.

2. **Fixed Point Vehicle Identification:** This method, also known as Point Vehicle Time Detection (PVTD), Anonymous Re-identification (ARID), or simply re-identification, employs a variety of technologies to identify individual vehicles at a fixed point before the queue and then again at the Primary Inspection booth or at various points along the queue. The identification process involves both human-involved methods such as timestamped cards, toll receipts, and human observations, and automated methods including Radio Frequency Identification (RFID), Automated License Plate Recognition (ALPR), and combinations of technologies like ARID Wi-Fi or Bluetooth readers supported by wired or wireless communications.⁴

The travel time between two points is determined by the time difference between two timestamps. The wait time attributed solely to the queue (referred to as the "experienced travel time") can be calculated by subtracting the average time required to travel that distance under optimal conditions. This approach is particularly suited for the calculation of wait time data for archival purposes. However, in terms of real-time measures, the data becomes outdated by the time the vehicle reaches Primary Inspection.

The lag time is reduced to the time it takes for a vehicle to travel between readers. To enhance accuracy, predictive elements can be integrated into the calculation, offering a projected delay. This results in a "predicted travel time" that more accurately reflects the wait time expected for vehicles just entering the queue. The vehicle re-identification approach offers flexibility in terms of what segments are measured, as readers can be placed at any point in the crossing process. ARID, a type of Fixed Point Vehicle Re-identification, ensures that the unique identifier provided by the vehicle or technology does not compromise the privacy of the individual.

3. **Dynamic Vehicle Tracking:** Dynamic Vehicle Tracking employs wireless signals to continuously monitor a vehicle's position as it moves along its journey. The vehicle's location, captured through GPS, is either sent to a central server via a Wi-Fi connection using cellular infrastructure or recorded directly on the vehicle or device for subsequent retrieval. Unlike fixed-point re-identification, which captures location at specific points, this method records or transmits the vehicle's location throughout its entire path. The collected data is analyzed to calculate the distance traveled by the vehicle over specific time periods as it approaches the border. If analyzing by segments, the times for each segment within the border area are aggregated to estimate wait time.

This technique is particularly effective for gathering historical data to assess performance. Nonetheless, it may encounter the same timing issues as vehicle re-identification; the data might become outdated by the time the vehicle arrives at the Primary Inspection due to delays experienced en route.

As with the vehicle re-identification method, it is possible to include predictive components to the data analysis algorithm that allow the provision of a forecast delay. Additional flexibility to measure wait times along individual segments of the crossing process can be achieved by "geofencing" (defining virtual geographic zones) specific regions at each crossing.

For instance, at a point along a roadway, unique identifying data can be made available by a mobile phone (data source) inside the vehicle to a Wi-Fi reader on the roadside (data collection mechanism) that transmits the data through a cellular phone network (communications infrastructure) to a server sitting on the cloud (data warehouse). These steps are then repeated at one or more additional points along the roadway. When the same unique identifier on the mobile phone is read at one or more points down the road, a travel time can then be calculated for the distance between two points. This travel time data is then

⁴ Under the Strengthening Mobility and Revolutionizing Transportation (SMART) grant program Stage 1 Notice of Funding Opportunity (NOFO), ALPR technology is not eligible for funding. A similar requirement is expected to be present in the Stage 2 SMART Grants NOFO.

analyzed, processed, repackaged into useful information, and made available via an app or website (data dissemination) to the user.

3.3 Technologies Overview

This section sets the stage for the review of the systems currently in place to measure and disseminate BWT across the northern and southern borders of the United States. This section provides standard definitions and descriptions of the technologies that are currently in place and/or being considered, which will be described with location-specific examples in Section 3.4. Understanding these technologies is critical for assessing their application and effectiveness in different border contexts.

The technologies covered in this section include those used to generate, collect, and transform data into information, as well as the most common information dissemination technologies that are currently in use. These technologies, individually or in combination, form the backbone of current BWT measurement systems, offering a range of capabilities from historical data analysis to real-time traffic management. The most recent survey of common technologies for border wait time measurement applications was conducted by TTI in 2017 in a White Paper for SANDAG. The paragraphs that follow focus on those technologies that remain in use (state-of-the-practice) and those that have recently been successfully tested in the field.^{2,5}

3.3.1 Data Collection and Traffic Monitoring Technologies

Several technologies are employed in a BWT measurement system to collect, transmit, process, store, analyze, and disseminate data. A BWT data collection system is a synergistic assembly of these technologies, working in unison to gather the necessary data for measuring border crossing and wait times, and to relay pertinent information to its diverse users.

Border crossings are unique infrastructural environments with operational characteristics that greatly differ from other transportation infrastructures, such as domestic highway networks. The planning and operations at these crossings are shaped by the involvement of multiple entities and jurisdictions (e.g., border agencies, transportation agencies, facility operators) on both sides of the border. While border crossings share some common features with each other, each location possesses unique operational, infrastructural, environmental, and security attributes.² For instance, some crossings cater to commercial and passenger vehicles as well as pedestrian traffic, while others may exclusively service one mode or rail traffic.

Consequently, the selection of technologies for a BWT system must consider the distinctive characteristics of the location, the continual advancements in technology, and the needs of the various stakeholders who rely on the border crossing information for operational and planning purposes, including traveler information.²

The subsequent sections provide an in-depth look at the array of technologies deployed for gathering, analyzing, and sharing data on border wait times. These tools, whether used in ongoing operations or under evaluation in pilot programs, are crucial to the functionality of BWT measurement systems. They enable a comprehensive suite of services, from analyzing historical traffic patterns to managing traffic flows in real-time, thereby forming the critical infrastructure needed for effective border wait time management.

² SANDAG. 2017. *Border Wait Time Technologies and Information Systems White Paper*.

⁵ Several technologies included in the 2017 survey are not included here, as they are either not currently in use for the purpose of measuring border wait times, or consolidated into other technologies.

RFID (Radio Frequency Identification)

Radio frequency identification (RFID) technology uses electromagnetic fields to automatically identify and track tags attached to objects. It is a technology widely used to measure border wait times. RFID can be used to re-identify vehicles that carry RFID tags, such as toll tags or transponders, at multiple points along the crossing process. By comparing the timestamps of the tag detections, the travel time and wait time of the vehicles can be calculated.

RFID has been used for over 30 years in vehicle identification, leveraging dedicated radio frequencies to detect automated toll tags. Commercial vehicles, in particular, stand to gain from RFID due to the high penetration of RFID tags for various pre-screening programs, such as CBP's Free and Secure Trade program (FAST). This technology is also appropriate for passenger vehicles at locations where tolling or vehicle registration programs require the use of RFID tags. As a result, the re-use of transponders already in vehicles crossing the border for travel time and border wait time calculations is a possibility, though will be specific to the geography of the POE; for example, at the Cascade Gateway POEs, toll tags are in use by the general public within WA, but are not in use in BC. TTI recently conducted a short pilot test at the Paso Del Norte Bridge border crossing between El Paso and Ciudad Juarez to evaluate the penetration rate of REPUVE (Mexican National Vehicle Registry) RFID tags among passenger vehicles crossing the border. This pilot demonstrated that using an RFID system to estimate BWT for passenger vehicles is feasible and could be used to segregate speeds on different traffic lanes (e.g. SENTRI vs. Ready vs. Standard lanes), an advantage over the Bluetooth/Wi-Fi reidentification systems.⁶ An extended pilot study is underway at the same location.

RFID readers, strategically positioned along the roadside or above the roadway using existing infrastructure, perform optimally when near the target vehicle in a single travel lane. However, their accuracy is compromised with distance and obstructions. The range of these systems, contingent on the generation and type of RFID tag and reader, is approximately 12-15 meters.

Privacy is a paramount concern with RFID technology. To address this, RFID tag IDs are typically truncated before data transmission to the managing agency, preventing the tag ID from being matched to the tag owner in the agency's database. Emerging Connected Vehicle (CV) technologies use similar detection technology, but privacy restrictions may render CV technology unsuitable for segment travel time data collection.

The advantages of RFID include:

- High accuracy and reliability of travel time and wait time measurements.
- Detailed data regarding movements of vehicles on approach to and within inspection facilities.
- Support for multiple measurement points and segments.
- Potential to leverage existing tags and readers that are already used for other purposes at border crossings.

The challenges and limitations of RFID include:

- Requirement for the installation of equipment in individual vehicles and on the roadside, which could be costly and logistically taxing when roadway geometry is reconfigured or traffic patterns change.
- Dependence on the penetration rate of RFID tags among border crossers.
- Potential interoperability issues between different RFID protocols and standards.
- Privacy concerns regarding the collection and use of vehicle identification and location data.
- Risk of interference, vandalism, or theft of the equipment.

² SANDAG. 2017. *Border Wait Time Technologies and Information Systems White Paper*.

⁶ Vargas, E., Samant, S., Ruback, L. Guzman, A., Aldrete, R., Berlanga, A., Macias, R. (2023) *Measuring wait times using RFID technology on passenger vehicles lanes*. Texas A&M Transportation Institute. In print.



Figure 9. RFID Technology for BWT Measurement

Bluetooth

Bluetooth wireless technology, a short-range communication system, was initially designed to replace cables connecting portable and/or fixed communication devices while ensuring high security levels. Commonly found in devices such as smartphones, car hands-free kits, tablets, wireless headsets, and more, Bluetooth technology's key attributes include robustness, low power consumption, and cost-effectiveness.

Having been in use for over two decades, Bluetooth is considered a mature technology. The Bluetooth specification provides a standardized structure for a diverse range of devices to connect and communicate. One of its notable features is its global acceptance, enabling any Bluetooth-enabled device to connect with other such devices in proximity, almost anywhere in the world. Data sources for Bluetooth signals encompass devices such as cellular phones and other Bluetooth-equipped mobile devices, vehicles equipped with Bluetooth, and Bluetooth accessories like headsets and speakers. While not all vehicles contain mobile phones emitting Bluetooth signals, the proportion that does (also known as the penetration rate) is generally sufficiently dense to obtain meaningful travel time data by tracking these devices' signals.

Bluetooth-enabled devices can interact with other such devices within a range of 1 meter to about 100 meters, contingent on the class of radios attached to the device. Bluetooth based systems are particularly suited for vehicle/device re-identification detection methodologies and have undergone extensive testing in recent years and have been permanently for border crossing time applications at crossings along the U.S.-Canada and U.S.-Mexico borders, as is described later in this chapter.

The Bluetooth protocol employs a unique electronic identifier in each device, known as a Media Access Control (MAC) address. Bluetooth readers, using a refresh rate defined by the software within the reader, can search for nearby devices and obtain the MAC addresses of Bluetooth-enabled devices, along with a timestamp. Given the uniqueness of each MAC address, traditional re-identification matching algorithms, like those described for RFID tracking, can be employed to estimate travel time between two locations on a roadway. As MAC addresses are not directly linked to any user's personal information, privacy concerns are minimized.

To support Bluetooth data collection methodologies, roadside data collection hardware, or Bluetooth readers, must be installed along the queue(s) at carefully selected locations along the border crossing process.

The advantages of Bluetooth include:

- **Short-Range Communication:** Bluetooth technology provides short-range communication, making it suitable for tracking vehicles in a specific area like border crossings.
- **Global Acceptance:** Bluetooth technology is globally accepted, which means any Bluetooth-enabled device can connect with other such devices almost anywhere in the world.
- **Unique Identifier:** Each Bluetooth device has a unique electronic identifier (MAC address), which can be used for vehicle/device re-identification detection methodologies.
- **Privacy:** Since MAC addresses are not directly linked to any user's personal information, privacy concerns are minimized.

The challenges and limitations of Bluetooth include:

- **Limited Location Precision:** The range of Bluetooth communication is a radius of about 100 meters, which means the device's location is not necessarily pinpointed with precision, but rather within a 100 meter range before and after the reader location. This also means that Bluetooth technology cannot detect with precision the exact lane where a vehicle is queuing, a drawback when trying to segregate the crossing times of different but adjoining lane types (e.g.. standard vs. NEXUS).
- **Penetration Rate:** Experience on the U.S.-Mexico border has shown that on comparison to other technologies like Wi-Fi, Bluetooth has a lower penetration rate, meaning it detects fewer mobile devices. To overcome this limitation, TTI has deployed systems which use both Bluetooth and Wi-Fi simultaneously at border crossings in El Paso, Texas. Additionally, many off-the-shelf products now include Bluetooth and Wi-Fi readers within the same enclosure.
- **Dependence on Hardware:** Bluetooth data collection methodologies require the installation of roadside data collection hardware, or Bluetooth readers, which could be a logistical challenge when roadways are reconfigured, or traffic patterns change.
- **Limited to Discoverable Devices:** Traditional Bluetooth readers can only detect discoverable Bluetooth signals, limiting the number of devices that can be detected. New generation Bluetooth sensors are also able to pick up Bluetooth Low Energy (BLE) signals, which have shown higher penetration rate than traditional Bluetooth devices.



Figure 10. Bluetooth Reader Technology for BWT Measurement

Wi-Fi

Wi-Fi, like Bluetooth, is a short-range communications technology designed to facilitate communication among devices while maintaining high levels of privacy. It is commonly integrated into modern devices such as smartphones, hands-free kits in cars, tablet computers, and other media streaming devices. Similar to Bluetooth, the Wi-Fi signal emitted from these devices has made Wi-Fi a highly viable candidate technology for capturing the travel time of vehicles when drivers or passengers carry these devices, or when vehicles have Original Equipment Manufacturer (OEM) or third-party Wi-Fi capabilities.

Wi-Fi is currently widely available in mobile devices and for roadside reader applications. A device must have Bluetooth or Wi-Fi enabled to be visible to the network and available for detection and be within range of the Point Vehicle/Time Detection (PVTD) device (approximately 500 ft.). Mobile device users frequently leave Wi-Fi enabled on their devices, versus Bluetooth which is may be disabled when not in use. Tests conducted in the past 10 years have demonstrated that the penetration rate of Wi-Fi can be up to 20% greater than Bluetooth in free-flow conditions.⁷ Wi-Fi deployments for passenger vehicle border crossing wait time measurement in Texas show a similar trend.

As a result, Wi-Fi alone or in combination with Bluetooth provides a higher probability data point for roadside readers. Numerous applications of Wi-Fi for border wait time measurement are available along the U.S.-Mexico border. Another advantage of Bluetooth and Wi-Fi systems is that, in bumper-to-bumper traffic, these technologies can detect and track devices in vehicles at locations where the license plate is not visible to technologies such as Automatic License Plate Recognition (ALPR).

In terms of deployment considerations, Bluetooth and Wi-Fi readers should be deployed at strategic locations along the roadway(s) leading to the crossing where the queue forms. The factors that drive these locations include typical and maximum queue lengths and patterns, and roadway configuration. For example, readers

⁷ In a series of 2013 Danish travel time trials in Aalborg, Denmark using Bluetooth, Wi-Fi, and a combination of the two, data from the combined technologies trial indicated that 20% more vehicles were identified by Wi-Fi than Bluetooth (Source: ITS International, October 2013. "Bluetooth and Wi-Fi Offer New Options for Travel Time Measurements").

would be deployed at the end of the typical queue on each of the roadways where the queue forms, and additional readers may be required at intersections where two or more roadways carrying queue traffic merges. Finally, readers would be deployed at the exit from the border crossing. Having multiple intermediate readers along the approaches improves the responsiveness of the wait time reporting algorithm to report most current information to the roadway users.

The advantages of Wi-Fi include:

- Wi-Fi has a higher device detection rate compared to Bluetooth, making it more effective in dense environments.
- Wi-Fi signals can be detected from a variety of devices such as smartphones, vehicles with Wi-Fi capabilities, and other Wi-Fi enabled devices.
- Like Bluetooth, Wi-Fi is globally accepted and any Wi-Fi-enabled device can connect with other such devices almost anywhere in the world.

The challenges and limitations of Wi-Fi include:

- Similar to Bluetooth, Wi-Fi data collection methodologies generally require the installation of permanent roadside data collection hardware, which could be a logistical and costly challenge to physically relocate when roadways are reconfigured, or traffic patterns change. Although temporary portable Bluetooth/Wi-Fi reader systems are available that could be used to measure BWT, they tend to be more vulnerable to vandalism.
- Similar to Bluetooth, Wi-Fi technology cannot detect with precision the exact lane where a vehicle is queuing, a potential drawback when trying to segregate the crossing times of different but adjoining lane types (e.g., standard vs. NEXUS).
- While Wi-Fi MAC addresses can be made anonymous, privacy concerns may still exist due to the ability to track the movement of Wi-Fi enabled devices.
- Wi-Fi operates in crowded frequency bands which can lead to interference from other devices, potentially affecting the reliability of the data.
- Wi-Fi-enabled devices generally consume more power compared to Bluetooth, which could limit its use in certain scenarios.

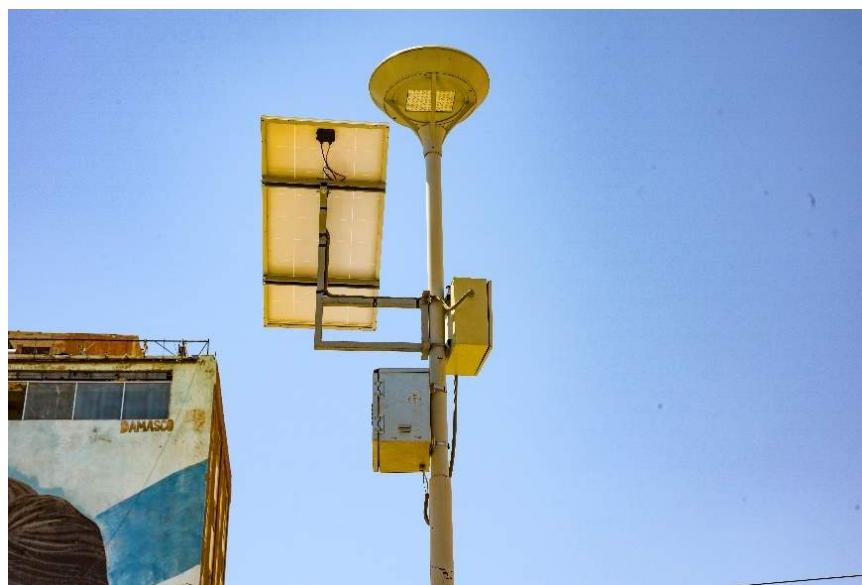

Figure 11. Wi-Fi Technology for BWT Measurement

Inductive Loop Detectors

Inductive Loop Detectors (ILDs) are used in traffic management to detect the presence and movement of vehicles through electromagnetic fields generated by wires embedded in the roadway. While ILDs offer a high detection rate, meaning they are effective at consistently identifying the presence of vehicles over them, their application in border wait time measurement systems is challenged by the unique traffic conditions at borders, such as frequent stops and starts. This high detection rate refers to their ability to accurately sense when vehicles are directly above them, which is crucial for traffic counts and speed measurements under normal flow conditions but becomes less effective in congested, stop-and-go scenarios typical of border crossings. The need for physical modification of the road surface for installation and maintenance further complicates their use in dynamic environments like borders, where traffic patterns can change rapidly and unpredictably.

The advantages of ILD include:

- Consistently high vehicle detection rate under normal traffic flow.
- Low initial cost.
- No privacy or security concerns due to lack of personal data capture.

The challenges and limitations of ILD include:

- Poor performance in stop-and-go traffic conditions common at borders.
- Significant costs and logistical challenges for installation and maintenance.
- Limited ability to adapt to changing lane configurations or classify vehicles without specialized processors.
- Reduced accuracy and reliability for border wait time applications compared to technologies like Bluetooth or Wi-Fi, since ILD cannot identify a unique vehicle or device. The ILD systems are capable of detecting the presence of a vehicle and in effect the count of vehicles crossing the detectors and also speed of vehicles with multiple readers. The vehicle count is in turn used to compute queue length and eventually wait times. However, in the stop-and-go conditions at the border, the ILD detectors are prone to missed counts and multiple-counting (double counting) of vehicles due to the extended presence of the vehicle in the detectors detection zone. There have been advances in ILD technologies in which unique profiles/signatures can be detected for each vehicle – please see the *Concept Exploration and Recommendations Report* for additional details on this technology.

In the context of the current Cascade Gateway ATIS, the use of ILDs illustrates the limitations of static traffic management infrastructure in dynamic border environments. Their fixed locations and limited vehicle classification capabilities have led to complications, impacting the system’s ability to adapt to evolving port entry configurations and accurately measure wait times.



Figure 12. Inductive Loop Detectors

Magnetometers

Wireless magnetometers, such as those manufactured by Sensys Networks, are typically designed for use at intersections, particularly near the stop line, and in conditions of free-flowing traffic. The stop line scenario resembles that of border crossing checkpoints, where vehicles must come to a halt near the stop line for detection. These magnetometers can be strategically placed in each lane near the checkpoint to cover multiple lanes. Sensys provides both a free-flow and stop line versions of these sensors, indicating that magnetometers can be familiar with border crossing scenarios. However, and based upon testing of similar equipment in a border crossing environment, TTI found that magnetometers suffered from accuracy issues, and did not work properly under the test condition and overcounted vehicles by more than 80%.⁸

The advantages of magnetometers include:

- See section above for Inductive Loop Detectors.
- Potentially lower initial cost than inductive loop detectors, given that the sensors operate wirelessly and as such, have reduced conduit infrastructure needs.

The challenges and limitations of magnetometers include:

- See section above for Inductive Loop Detectors.
- The sensors operate wirelessly, so suffer from issues related to battery life and wireless interference.

⁸ Middleton, D., Charara, H., Cornejo, L. and Samant, S. (2014). *Investigation of Detectors for Border Traffic Counts*. Center for International Intelligent Transportation Research. Texas A&M Transportation Institute. El Paso, TX. <https://static.tti.tamu.edu/tti.tamu.edu/documents/186054-00008.pdf>. Consulted on February 16, 2024.



Figure 13. Magnetometer Technology Testing at a Border Crossing ⁸

Global Positioning Systems

The Global Positioning System (GPS) is a versatile technology that plays a pivotal role in tracking and navigation across various devices, including smartphones, navigation systems, and In-Vehicle Units (IVUs) in commercial vehicles. GPS's unique advantage lies in its ability to provide location data without the need for roadside infrastructure, utilizing cellular, satellite, or short-range communications for data transmission. This capability is helpful for the purposes of calculating cross-border travel times. Electronic Logging Devices (ELDs), mandated by the US Federal Motor Carrier Safety Administration for specific commercial vehicles, leverage GPS to track driving hours, ensuring compliance with regulations.

A Federal Highway Administration (FHWA) study in 2009 underscored GPS's value in border wait time measurements, highlighting its precision in tracking vehicle movements and the importance of private sector data. However, collaboration with the private sector is essential for accessing device-generated data in anonymized manner, as individual vehicle positioning data is considered commercially sensitive information. As a result, freight carriers are often reluctant to share their data.

Recent protracted wait times at U.S.-Mexico border crossings, especially in Texas, have prompted carriers to consider sharing anonymized GPS data to enhance border crossing time measurement systems. However, these initiatives have faced challenges in implementation. The growing implementation ELDs introduces a potential for accessing rich anonymized GPS data, offering a promising avenue for improving measurement accuracy and efficiency.

The advantages of GPS include:

- Precise tracking of cross-border movements with the potential for detailed analysis..
- Independence from fixed infrastructure, allowing for flexible data collection.
- Collaboration with the private sector can enrich data sources.

The challenges and limitations of GPS include:

- Although GPS offers significant precision, it is not precise enough for lane by lane measurement. Most common GPS used today are typically accurate to within a 4.9 m (16 ft.) radius under open sky, which is not sufficient for lane separation.
- Reliance on vehicle equipment installation and third-party data management services, which generally comes at the expense of annual or monthly fees.
- Privacy concerns and commercial sensitivity around fleet GPS data.
- Potential difficulties in data normalization and outlier management.

Crowdsourced Data

Crowdsourcing is a method that harnesses the collective intelligence, knowledge, or experience of a group of people or their devices to answer questions, solve problems, or manage processes. Crowdsourced data utilizes collective inputs from individuals and their devices, offering valuable insights for travel time data collection and dissemination, particularly in border wait time measurement. By leveraging location-aware mobile devices, vehicles become mobile probes, providing real-time data on their location and speed.

This method stands out for its real-time tracking capabilities, precision, and avoidance of traditional data collection challenges. However, it faces its own set of challenges, including complex data management, reliance on high traffic volumes for accuracy, and specific issues at border crossings like congestion and international roaming impacts. Transportation agencies often partner with third-party providers like INRIX, HERE and Streetlight to access aggregated data, streamlining planning and operations.⁹ Additionally, platforms like Google Maps and Waze are popular for real-time traffic updates, supported by Application Programming Interfaces (APIs) for data integration. Similar APIs from Bing Maps, HERE, TomTom, and others provide similar reference data.

Crowdsourced data accuracy for travel time estimation on highway and street networks has been found to be nearly as accurate as traditional sensor networks, as long as traffic volumes are not low (e.g., rural highways). However, the accuracy of crowdsourced data alone remains significantly limited in the context of estimating border wait times when compared to re-identification-based wait time measurement systems. This could be the result of one or more of several factors at play at border crossings, including congestion, international roaming for cell phone-based data, speed differences between different types of lanes, etc.

As noted in the Hybrid Systems section, despite its limitations in the context of border wait time measurement, crowdsourced data, especially when combined with traditional sensor data, has the potential to enhance the comprehensiveness and accuracy of traffic monitoring systems. A recent study that examined market-available crowdsourced Wejo CV data for border crossing time estimation, determined that although the current availability of data at border crossings was very limited, future market penetration growth may allow its use as a supplement to existing border wait time measurement systems.¹⁰

The advantages of crowdsourced data include:

- Real-time tracking of individual vehicles.
- More precise and timely speed and travel time estimates.
- Avoidance of challenges associated with data access and management.

The challenges and limitations of crowdsourced data include:

⁹ FHWA (2022). *FY 21 Annual Technology Transfer Report*. <https://www.transportation.gov/sites/dot.gov/files/2023-10/DO%20T2%20Annual%20Performance%20Report%20FY21.pdf>

¹⁰ Texas A&M Transportation Institute (2022). *Exploring Crowdsourced Big Data to Estimate Border Crossing Times*. <https://static.tti.tamu.edu/tti.tamu.edu/documents/185921-00011.pdf>

- Complex data collection and cleaning tasks.
- Dependence on traffic volumes for accuracy, and even under ideal volume circumstances, location accuracy is not enough to segregate wait times by lane.
- Lack of transparency in terms of data sources used by vendors.
- Difficulty in determining sample rate as a percentage of total traffic volume.
- Data ownership issues, including highly restrictive licensing agreements and which generally comes at the expense of annual or monthly fees.
- Accuracy of crowdsourced data alone for estimating border wait times is inferior to traditional, infrastructure-based systems, based on TTI's findings at the southern border.
- Potential issues at border crossings, including congestion, international roaming for cell phone-based data, and speed differences between different types of lanes at border crossings.

LiDAR Traffic Counters

LiDAR (Light Detection and Ranging) technology has demonstrated highly accurate results for vehicle detection and counting in border crossing environments. This technology excels in accurately counting vehicles, including in complex traffic scenarios such as those found at international border crossings where traditional sensors might falter due to stop-and-go conditions. As noted under the Hybrid Systems discussion, real-time traffic volume counters are an invaluable addition to advanced border wait time measurement systems that incorporate short term prediction of wait times to overcome the challenge that re-identification technologies face in providing real-time measurements on their own (i.e., their data becomes outdated by the time the vehicle reaches Primary Inspection). Real-time volume counters not only allow to measure the throughput of the border crossing, but also to estimate the number of vehicles within the border crossing, and potentially determine an inspection lane's open/closed status.

One specific device that has been in operation at the Ysleta/Zaragoza and Bridge of the Americas (BOTA) Ports of Entry (POE) in El Paso, Texas since 2017 is the LeddarTech IS16, which is an LED-based low-cost scanner that was identified for its unparalleled accuracy in such environments, although it required firmware modifications and the development of a custom software application to fully meet the needs of automated border traffic counts.^{11 12} This technology addressed the unique challenges of measuring traffic volumes at border crossings in real time, in addition to other potential applications, such as remotely determining inspection lane status (i.e. open or closed), and developing short term border wait time prediction.

LiDAR detection works in a similar fashion as ILD detection, with the difference being that the LiDAR raw detections are processed by an edge computer to account for the extended presence of vehicles in order to report a true vehicle count. Ideally, one LiDAR sensor would be expected to cover one lane at regular intervals along the approach to the crossing. However, in practice this expectation might be unrealistic as the LiDAR sensor needs to be mounted overhead above the lane. As a practical solution, it is generally recommended that the LiDAR sensors be installed over each lane at the entry and exit of the crossing. This configuration would provide a true count of vehicles waiting in queue at the crossing, while also providing easier mounting and connections to power/communications.

The advantages of LiDAR include:

¹¹ Middleton, D., Charara, H., Cornejo, L. and Samant, S. (2019). *Expansion Of Commercial Truck Counts at The Border*. Center for International Intelligent Transportation Research. Texas A&M Transportation Institute. Texas A&M Transportation Institute. El Paso, TX. <https://static.tti.tamu.edu/tti.tamu.edu/documents/185917-00017.pdf>

¹² Middleton, D., Charara, H., Cornejo, L. and Samant, S. (2015). *Long-Term Border Traffic Counts*. Center for International Intelligent Transportation Research. Texas A&M Transportation Institute. Texas A&M Transportation Institute. El Paso, TX. <https://static.tti.tamu.edu/tti.tamu.edu/documents/186045-00009.pdf>

- The LeddarTech IS16 sensor showed exceptional accuracy in counting vehicles under varied traffic conditions, making it suitable for the dynamic environments of border crossings.
- Successfully tested in harsh desert conditions, the sensor's durability was enhanced with protective covers, proving its reliability over time with minimal maintenance requirements.
- Its low initial cost, combined with its robust performance in challenging environmental conditions, underscores its value.

The challenges and limitations of LiDAR include:

- Need for firmware modifications and the development of a custom software application to tailor to the specific needs and configuration of the POE.
- Regular cleaning of the sensor lenses was necessary to maintain accuracy, especially in lanes heavily used by commercial vehicles where diesel exhaust particulates could accumulate.

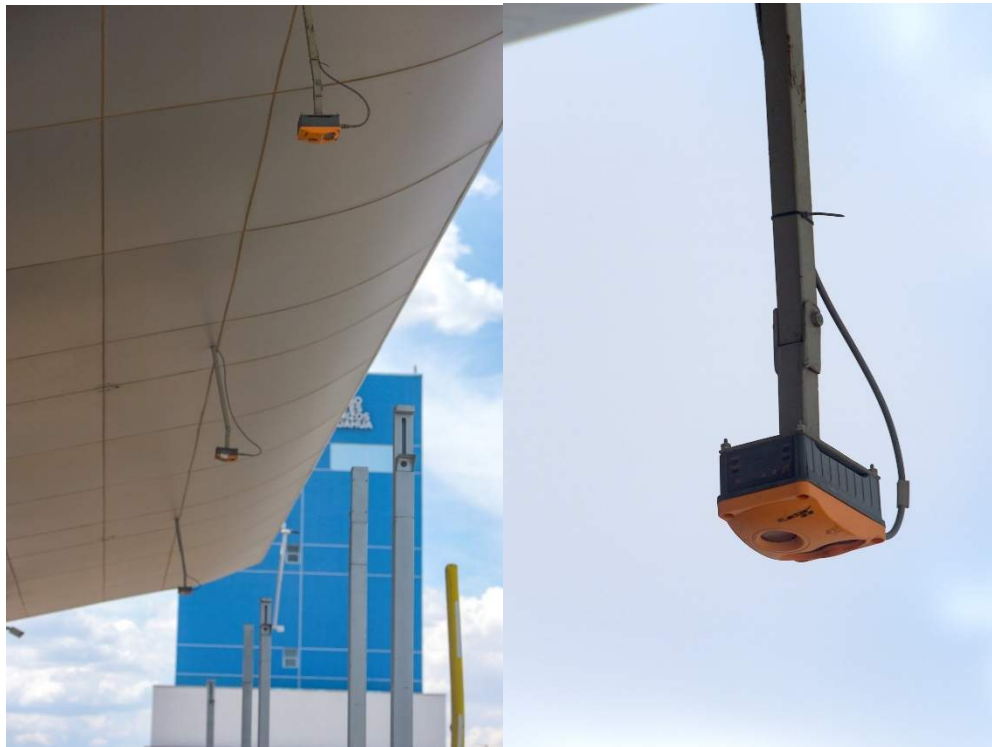

Figure 14. LiDAR Technology for Traffic Counts at a Border Crossing

Automatic License Plate Recognition (ALPR) Technology

Automatic License Plate Recognition (ALPR) technology is becoming essential within border security management frameworks. It streamlines border crossings by automating the capture and verification of vehicle license plates. Utilizing Optical Character Recognition (OCR), ALPR systems transform plate images into textual data for validation against various databases, supporting security screenings, traffic management, and law enforcement efforts.

Despite its advantages, ALPR's role in BWT measurement faces challenges due to border traffic's unique characteristics, such as slow movement and congestion, which hinder the technology's ability to accurately read license plates. This limitation, identified through extensive testing at both U.S.-Mexico and U.S.-Canada

borders, combined with the higher costs associated with ALPR systems compared to alternatives like Bluetooth and RFID, poses difficulties for widespread adoption in BWT measurement.

The challenges, limitations, and considerations of ALPR include:

- **Deployment Precision:** Implementing ALPR demands careful placement of cameras at the start of queues to ensure accurate travel time calculations.
- **Maintenance Responsibility:** Ownership of ALPR systems entails ongoing maintenance of the infrastructure, including cameras, antennas, and power units, often resulting in significant expenses.
- **Safety and Security:** Protecting ALPR equipment from theft or damage is crucial, considering its three to five year lifespan, which may fluctuate based on border environmental conditions.
- **Sustainability Concerns:** Historical experiences reflect concerns over the feasibility of sustaining long-term maintenance and security of ALPR technology, impacting its viability.
- **Privacy Issues:** The nature of ALPR data collection brings about privacy concerns, necessitating rigorous data protection protocols.
- **Cost Implications:** The high initial costs and need for regular maintenance challenge the practicality of ALPR systems for border security operations.
- **SMART Grant Funding Requirements:** The Stage 1 SMART Grants NOFO indicated that funds could not be used to purchase ALPR cameras or for enforcement. A similar requirement is expected to be present in the Stage 2 SMART Grants NOFO.



Figure 15. ALPRs at a Border Crossing

Video Analytics and AI in Border Traffic Management

The integration of video analytics and Artificial Intelligence (AI) at border crossings represents a significant leap forward in managing and mitigating traffic during extreme conditions. These technologies enable transportation agencies to swiftly process and analyze vast amounts of data, offering a proactive approach to adapt to changing traffic patterns effectively.

TTI recently had the opportunity to apply these innovations during unprecedented traffic congestion episodes at Texas border crossings derived from enhanced commercial vehicle safety inspections that resulted in extreme queues (> 5-miles).¹³ Utilizing Unmanned Aerial Vehicles (UAV) video and high-resolution satellite images, researchers used AI to enhance image resolution, enabling Machine-Learning-powered accurate vehicle counts and queue measurements. This effort has provided valuable insights into the dynamics of border traffic, improving the understanding of extreme queue lengths and travel times, and advancing the use of satellite imaging in traffic analysis.

Incorporating video analytics and AI at border crossings extends beyond satellite imagery and UAV video analysis. A pivotal application of this technology recently tested by TTI lies in utilizing image recognition from cameras positioned at the entry and exit points of border crossings.¹⁴ This setup enables the execution of vehicle and/or person re-identification algorithms, crucial for estimating border crossing or wait times accurately. By capturing and analyzing video footage in real-time, these AI-driven systems can identify specific vehicles or individuals as they enter and leave the border area, facilitating a seamless calculation of wait times. This method enhances the precision of border wait time assessments, offering a dynamic tool for traffic management agencies to optimize flow and reduce congestion. Leveraging video analytics for re-identification purposes underscores the evolving landscape of border management technologies, promising to further improve safety, efficiency, and the overall crossing experience by addressing and adapting to the intricate patterns of border traffic.

As advancements in transportation technologies continue, the deployment of video analytics and AI at border crossings is poised to transform how traffic management agencies predict and tackle operational challenges. This synergy of advanced technologies is expected to bring about significant improvements in safety, mobility, and efficiency in border transportation, highlighting the critical role of ongoing innovation in meeting the evolving demands of border crossing management. Given the relatively new but rapidly evolving nature of video analytics and AI technologies, the challenges they present in the context of border wait time measurement are also evolving.

The advantages of video analytics and AI include:

- **Enhanced Analytical Speed and Accuracy:** These technologies enable rapid processing and analysis of extensive datasets, allowing for immediate adaptation to fluctuating traffic conditions.
- **Accurate Wait Time Estimation:** By employing image recognition technologies at border entry and exit points, video analytics and AI can accurately re-identify vehicles and individuals, allowing for lane-by-lane measurement, and ensuring precise border crossing or wait times calculations.

The challenges and limitations of video analytics and AI include:

- **Complexity of Implementation:** Deploying these advanced technologies requires significant technical expertise, posing challenges in terms of system integration and operationalization.
- **Cost Considerations:** The initial setup, including purchasing high-resolution cameras and developing AI algorithms, can be moderately costly. Additionally, ongoing maintenance and updates may be required to periodically retrain algorithms.
- **Data Privacy and Security:** The collection, processing, and storage of data, especially personal

¹³ <https://ciitr.tti.tamu.edu/2022/11/10/keeping-ahead-of-the-curve-mitigating-extreme-traffic-events-with-advanced-technology/>

¹⁴ Galicia, D., Berlanga, A., Vargas E., Guzman, A., Turner, A., Aldrete, R. (In Print). *Measuring Pedestrian Border Crossing Time Through Advanced AI Modeling*. Center for International Intelligent Transportation Research. Texas A&M Transportation Institute. El Paso, Texas.

identification information captured through video analytics, raise privacy and security concerns that necessitate strict compliance with data protection regulations.

- **Environmental and Technical Limitations:** Factors such as poor lighting, adverse weather conditions, and the physical layout of border crossings can affect the effectiveness of video analytics and AI, potentially compromising the quality of data collected.

Despite these challenges, the potential of video analytics and AI to revolutionize border traffic management is undeniable. As these technologies continue to mature, it is anticipated that their applications will become more sophisticated, further enhancing border security and operational efficiency while simultaneously addressing and adapting to their inherent challenges.

Hybrid Systems and Artificial Intelligence

Hybrid systems in BWT measurement integrate a variety of technologies to enhance the flexibility, robustness, and accuracy of BWT assessments. These systems are characterized by their ability to integrate data from a wide array of sources—RFID, Bluetooth, Wi-Fi, crowdsourced information, LiDAR for real-time volume counts, status of inspection lanes, and Artificial Intelligence (AI) predictions, among others. Tailored to the unique operational complexities of each Port of Entry (POE), hybrid systems aim to refine wait time predictions by addressing the specific challenges identified in the introduction, such as expected traveler wait times.

For instance, the Otay Mesa POE in California and the Free Trade Bridge in Los Indios, TX utilize a hybrid approach for commercial vehicles by combining RFID technology near the border, suited for roads predominantly used by commercial traffic, with Bluetooth systems on mixed-traffic approaches. This strategy extends RFID coverage cost-effectively, overcoming limitations in sampling rates due to varied roadway geometries and traffic conditions.

Another example of a hybrid system is the novel system proposed for the City of El Paso International Bridges ITS expansion project, described in more detail later in this chapter.¹⁵ This advanced solution integrates RFID/Bluetooth/Wi-Fi for vehicle re-identification, LiDAR for real-time traffic volumes, inspection lane status, and crowdsourced traffic information, all processed through Machine Learning (ML) to offer an in-depth view of traffic flows and accurate travel time predictions. Originally developed by TTI, this ML-based system concept combines these diverse data sources to effectively estimate the "predicted travel time" discussed in Section 3.2.2, and addressing the limitations inherent in re-identification systems.¹⁶ It also utilizes crowdsourced data from platforms like INRIX and Google to calculate travel times from specific origins up to the border and from the border to destinations, merging these insights into a comprehensive cross-border trip travel time forecast. **Figure 16** aims to illustrate the flow of these diverse data inputs into a centralized processing system (the cloud), where ML algorithms generate short-term "predicted travel times" for each segment of a border crossing trip. Envisioned as a holistic online platform, it aims to mitigate congestion at the El Paso- Ciudad Juarez crossing, providing a centralized, user-friendly access point for stakeholders to access real-time traffic volumes, wait and crossing times, and enabling route planning for both commercial and private users.

¹⁵ City of El Paso (2019). *El Paso Intelligent Transportation System Ports of Entry Concept of Operations*. City of El Paso, El Paso, TX.

¹⁶ Samant, S. (2018). *A New, Web-Based Platform to Alleviate Cross-Border Traffic Congestion*. Texas A&M Transportation Institute. El Paso, TX. <https://ciitr.tti.tamu.edu/2018/06/14/a-new-web-based-platform-to-alleviate-cross-border-traffic-congestion/>

The advantages of hybrid systems and AI include:

- Merges multiple data sources for improved BWT prediction accuracy.
- Supports real-time traffic management and tailored solutions for each POE.
- Provides point-to-point cross-border trip traveler information, and not only BWT.

The challenges and limitations of hybrid systems and AI include:

- Integrating and managing diverse data sources adds complexity.
- Rapid technological advances require ongoing system updates.

This holistic strategy not only seeks to improve current traffic and wait time assessments but also facilitates future infrastructure planning, thereby promoting more efficient cross-border movement, reducing congestion, and improving air quality.

Online Portal for Sharing Traffic Data Internationally to Stakeholders and the Traveling Public

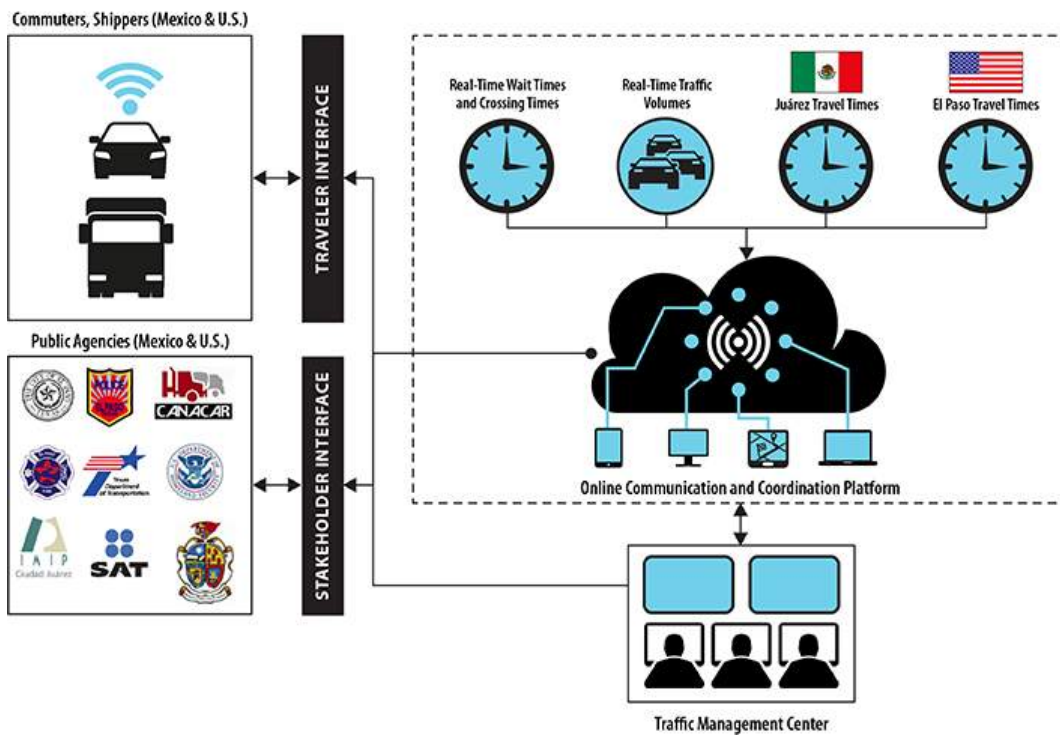

Figure 16: El Paso Hybrid BWT System and Online Communication and Coordination Platform¹⁷

Emerging Technology: The Michigan – Ontario Autonomous and Connected Vehicle Testbed

Michigan and Ontario, along with their transportation departments, are partnering to introduce greener technologies at the border. This multi-year effort involves collaboration between Michigan's Department of Transportation (MDOT) and Ontario's Ministry of Transportation, supported by the Michigan Office of Future Mobility and Electrification (OFME) and Ontario Vehicle Innovation Network (OVIN). Among the objectives of this initiative that may potentially impact BWT management include:

¹⁷ Samant, S. (2018). *Web-Based Platform to Alleviate Cross-Border Traffic Congestion*.

- Addressing challenges faced by individuals and goods during various types of border crossings (land, air, and water) and investigate how transportation technologies can provide solutions.
- Creating an implementation roadmap, outlining the necessary steps to establish cross-border pilot programs for transportation technologies.

OVIN, through Ontario Centre of Innovation (OCI) and Federal Bridge Corporation Limited (FBCL), has signed a Memorandum of Understanding (MOU) to enhance their partnership. This MOU will investigate ways to facilitate safe and efficient movement of people and goods across the border, utilizing innovative automotive and mobility technologies.

As part of this effort and in support of OVIN, the University of Windsor and the telecommunications company TELUS have teamed up in a \$5 million partnership to push forward 5G research in agriculture, advanced manufacturing, and connected vehicles. A significant focus of this effort is on enhancing connected vehicles for smooth cross-border travel using 5G technology. This technology, known for its high data speed and reduced latency, can enable vehicles to communicate more effectively with each other and with infrastructure (such as traffic signals and potentially sensors at border crossings). This improved communication can potentially help in measuring BWT by allowing for real-time data sharing and processing, which in turn can lead to improved operations, and smoother and faster border crossings for both individuals and goods. By working with OVIN, OEMs, and policymakers, the initiative aims to address congestion and supply chain issues, ultimately driving innovation and efficiency in transportation and related sectors.

3.3.2 Border Wait Time Data Transmission Technologies

The seamless transmission of data from field devices to processing servers is crucial for the accurate and efficient delivery of information crucial for cross-border travelers and trade. Advanced data transmission technologies play a pivotal role in the swift collection, processing, and dissemination of BWT information, significantly influencing enhancing the crossing experience.

Two primary technologies underpin the landscape of BWT measurement systems: cellular communications and fiber optic networks. These technologies are indispensable in the modern border management toolkit, offering distinct advantages in terms of speed, reliability, and coverage.

- **Cellular Communications:** Cellular technology, particularly vital along the southern U.S.-Mexico border, facilitates the backbone for data transmission from field devices to central servers. Its adaptability, complemented by modems' roaming capabilities across Mexican and U.S. carrier networks, ensures an uninterrupted data flow across international borders. This technology is instrumental for real-time monitoring and management of border traffic, providing accurate and timely updates on wait times. Since BWT systems designed using RFID, Bluetooth/Wi-Fi or LiDAR don't need high bandwidth for data transmission and diagnostics monitoring, cellular communication with 4G LTE is sufficient for system operations.
- **Fiber Optic Networks and Wi-Fi Integration:** For wired solutions at border crossings, particularly along the northern U.S.-Canada border, fiber optic communications, with its high-speed data transmission capabilities is a highly effective alternative. This network serves as a reliable base for efficiently transmitting vast amounts of data. Wi-Fi technology, relying on fiber optics for backhaul connections, allows to significantly expands the coverage and accessibility of data collection points, enabling a broader and more comprehensive traffic analysis. However, the deployment of these technologies involves challenges, including the cost and complexity of

installation and maintenance.

- **Point-to-Point Wireless Communications:** For longer range (e.g., generally 10 km to 100 km, depending on the specific system) wireless transmission methods that can provide greater reliability and bandwidth than cellular, point-to-point wireless communications involve the use of transmission and receiving antennas on each end of the wireless link to transmit data. These systems can operate at various frequencies, such as 5 GHz similar to what is typically used for Wi-Fi, to higher frequencies like 60 GHz that offer increased data transfer rates, but result in great limitations the ability for the Radio Frequency (RF) signal to penetrate obstructions like walls. In general, these systems rely on line-of-sight, and performance can be significantly degraded if there are obstructions such as trees.

In conclusion, both cellular communications and fiber optic networks have proven to be highly effective data transmission technologies, each with its unique strengths suitable for effective BWT measurement systems. The selection of technology at each border crossing should be guided by a careful consideration of the existing infrastructure, the likelihood of future adjustments in roadway geometry that may require relocating field sensors, and the associated costs of deploying and maintaining these technologies. Given the diverse requirements and conditions at each crossing point, a hybrid approach that mixes and matches cellular and fiber optic solutions could offer the most flexible and cost-effective strategy. This tailored approach ensures that the chosen technology aligns with the specific needs and constraints of each location, thereby optimizing the management efficiency of the BWT system.

3.3.2 Information Dissemination Mechanisms and Technologies

There are currently three main categories of BWT information dissemination mechanisms. The first one includes traditional mass communication mechanisms, such as television, radio, and word of mouth. The second one includes field ITS devices, such as DMS/VMS, traditionally used to provide the driving public a variety relevant travel information, ranging from lane closures and air quality warnings to roadway travel times, and BWTs. The final and third category are internet-based dissemination platforms, including websites, mobile device applications, and social media.

Traditional mass communication mechanisms continue to be widely used by the traveling public to conveniently access BWT information, with abundant examples along both the U.S.-Canada and U.S.-Mexico border. Cross-border communities continue to rely on radio talk shows that report BWT obtained from a number of sources, ranging from official U.S. CBP wait times and other official BWT systems, to times reported by reporters and audience. For example, NITTEC compiles regional border wait time data and publishes estimated wait times through various channels, including television.

Several transportation agencies along the U.S.-Canada and U.S.-Mexico border relay the BWT information they collect to the traveling public through roadside DMS/VMS. Examples include the WSDOT and BC MOTI, and the Buffalo and Fort Erie Public Bridge Authority (Peace Bridge). On the U.S.-Mexico border, the practice is not as widespread, but it is increasing on both sides of the border, especially after the recent trend of increased southbound queues. TxDOT and the City of El Paso are in the process of expanding their Border Crossing Information System (BCIS) and implementing a dedicated BWT ITS that includes DMS/VMS on El Paso roadways to communicate crossing times at the different border crossings and provide options to the traveling public. The Fideicomiso de Puentes Internacionales of the State of Chihuahua (the international

bridge operator in Ciudad Juarez) disseminates BWTs obtained from the El Paso-Ciudad Juarez BCIS via DMS/VMS on the roadways leading to the border crossings.¹⁸

Finally, internet-based dissemination platforms have emerged as the most widely adopted by border and transportation agencies to disseminate the information from their BWT measurement systems, and by the traveling public to consume it. One example of a web-based official dissemination website include U.S. CBP's BWT page, which reports BWTs for southbound traffic on the U.S.-Canada border and northbound traffic on the U.S.-Mexico border¹⁹. On the U.S.-Canada border, other examples the WSDOT and BC MOTI websites, the WSDOT app, and the NITTEC website.^{20 21 22} On the U.S.-Mexico border, TTI operates the BCIS website (sponsored by FHWA, TxDOT, NMDOT, ADOT, and Caltrans) and reports northbound BWTs for the largest commercial border crossings on the U.S.-Mexico border, northbound and southbound BWTs for passenger vehicles in the City of El Paso, Texas.²³ The BCIS also serves as a repository of historical BWT information which is a valuable source of information for planning purposes.

A number of mobile device navigation applications leverage the BWT information from the web-based platforms to provide live traffic information to cross-border travelers. The data and methods used to calculate wait times vary according to the publisher of the information. The approach to calculating wait times differs based on the source, with many applications drawing on the CBP manually observed wait time estimations. These estimations are then enriched with a variety of data points, including crowdsourced input, live border crossing reports, historical wait time analysis, and algorithms informed by live video feeds. While this integration aims to provide a comprehensive view of border wait times, it is important to acknowledge a significant limitation in the CBP data's utility for real-time travel planning: CBP reports wait times on an hourly basis, which may not offer the granularity needed for immediate travel decisions. Although many users perceive the wait time information from these apps as being more accurate than CBP's official data, it is important to note that there have been no formal efforts to validate the accuracy of these alternative sources. Some examples include:

- **Bordify.** The app Bordify (<https://bordify.com>) shows the border wait times for all USA ports of entry provided by U.S. CBP, for passenger vehicles and pedestrians, along with social media reports from users.
- **U.S. CBP Border Wait Times.** This CBP app reports the information published on the CBP BWT website.
- **Border Traffic.** An app that provides near real-time videos of the San Ysidro (San Diego) / Tijuana and the Otay Mesa / Tijuana border crossings. It also features AccuWait, which generates estimated wait times using analytics of the videos, and My Alerts, which notifies users when wait times meet their criteria.

¹⁸ City of El Paso (2019). *El Paso Intelligent Transportation System Ports of Entry Concept of Operations*. City of El Paso, El Paso, TX.

¹⁹ <https://bwt.cbp.gov>. CBP's system relies primarily on times collected and reported by CBP officers based on visual traffic condition assessment and traveler surveys. However, for certain locations along the U.S.-Mexico border, CBP has adopted the practice of reporting the BWT for commercial vehicles measured by the TTI BCIS which is sponsored by FHWA, TxDOT, NMDOT, ADOT, and Caltrans.

²⁰ <https://wsdot.com/travel/real-time/border-crossings>

²¹ <https://www.th.gov.bc.ca/ATIS/>. However, since border wait time information has become unreliable, BC MOTI has stopped publishing information.

²² <https://www.nittec.org>

²³ <https://bcis.tti.tamu.edu>. TxDOT is in the process of expanding the BCIS to several other communities on the Texas-Mexico border, and the City of El Paso and Fideicomiso de Puentes Internacionales del Estado de Chihuahua are in the process of upgrading and expanding the BCIS in the El Paso-Ciudad Juarez area.

- **Niagara Border Crossing.** An app for showing wait times for border crossings of the Niagara River between the United States and Canada. Wait times are shown for all four of the bridges that connect Western New York with Southern Ontario. The app relies on wait times produced by Niagara International Transportation Technology Coalition (NITTEC).
- **CanBorder App.** An app to provide estimated wait times at select ports of entry in Canada and the U.S. The app relies on data published by the CBSA.
- **iTrack-Border:** A privately-developed application called iTrack-Border that helps travelers plan their border trips in advance by predicting future wait times at multiple border crossings between the two countries. It uses publicly available data (e.g., Statistics Canada data provided by CBSA and data from the Cascade Gateway Border Data Warehouse) and incorporates ML, AI, data science, and visualization techniques. The app not only displays historical BWT data, but also forecasts future wait times on a daily and hourly basis for border crossings between the U.S. and Canada.

Finally, there are several examples of social media groups and accounts that aggregate border crossing wait times information from users. These groups are part of a larger trend of local community organizing that seeks to fill the gap of inaccurate information published by official channels, and provide valuable, real-time information for residents of binational communities. Some examples include:²⁴

- **Reporte de Puentes (Bridges Report):** This is a Facebook group created by frequent cross-border users. It serves as a platform for border residents and users to post pictures, videos, and real-time information on the bridges and wait times.
- **Cómo está la línea, Tijuana (How's the line, Tijuana):** This is another community on the Baja California – California region side of the U.S.-Mexico border. It takes a similar approach to Reporte de Puentes, providing constant reports for border users.

3.3.3 Data Storage, Archiving and Reporting

Data Storage and Archiving

Data storage and archiving technologies have evolved significantly over the years, offering various solutions tailored to different needs. Efficient storage of the data collected by BWT measurement systems is essential for processing and analyzing large volumes of information. Common storage solutions include on-premises server and cloud-based platforms.

Many border transportation agencies maintain on-premises servers to store and process data collected by BWT measurement systems. These servers are equipped with high-capacity storage drives and robust security measures to ensure data integrity and accessibility. This solution provides more control over their data and infrastructure allowing them to customize configurations and security policies while providing low-latency access to the data.

Increasingly, border transportation agencies are adopting cloud-based storage solutions, leveraging the scalability and flexibility of cloud computing to store and manage large datasets. Cloud platforms offer benefits such as easy accessibility, automatic backups, and reduced infrastructure costs. Cloud storage offers virtually limitless scalability, allowing agencies to quickly scale up or down their storage capacity based on demand, while ensuring data durability and availability even in the event of hardware failures or natural

²⁴ Cruz, P. (2016). *Cross-border Community Organizing on the U.S.-Mexico Border*. Baker Institute for Public Policy. <https://www.bakerinstitute.org/research/social-media-tools-aid-border-users>

disasters. Some examples of cloud providers are Amazon Web Services (AWS), Microsoft Azure, and Google Cloud Platform.

For border transportation agencies to effectively report data collected by BWT measurement systems, it is crucial to aggregate the data at regular intervals. This aggregation process involves combining and summarizing the collected data to provide a comprehensive overview of border wait times within a specific timeframe. Many border agencies adopt a systematic approach to data aggregation, often aggregating the data every 10 minutes or every hour to ensure timely and accurate reporting. For instance, the U.S. CBP Border Wait Times system follows an hourly aggregation process. At the end of each hour, the system aggregates and averages the data collected over the previous hour, producing a consolidated report that reflects the average wait times during that period. This aggregated data provides valuable insights into traffic flow patterns, helps identify trends, and enables border agencies to make informed decisions regarding resource allocation and border management strategies. By implementing regular data aggregation practices, border agencies can enhance the effectiveness and reliability of their border wait time measurement systems, ultimately improving the efficiency of cross-border traffic management.

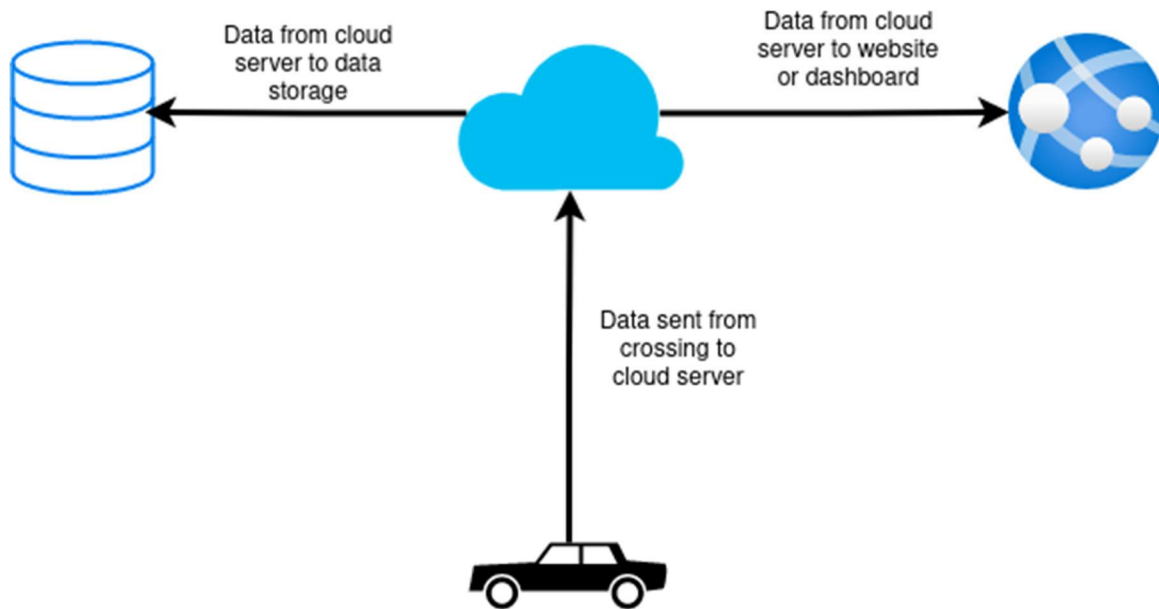

Figure 17: Example Data Flow of System Using Cloud Providers

Reporting and Visual Analytics

In order to better analyze the data collected by border wait time measurement systems, border transportation agencies often utilize visual representations of the data. Visualizations offer a powerful way to present complex information in a clear and easily understandable format, enabling stakeholders to quickly grasp trends, patterns, and insights from the data. Common visualizations used by border transportation agencies include charts, graphs, maps, and dashboards. These visual representations allow agencies to visualize key metrics such as average wait times, traffic volumes, and congestion levels at different border crossings. By leveraging visual representations of the data, border transportation agencies can gain valuable insights into border wait times, identify areas for improvement, and make data-driven decisions to optimize border operations and enhance the overall efficiency of cross-border traffic management.

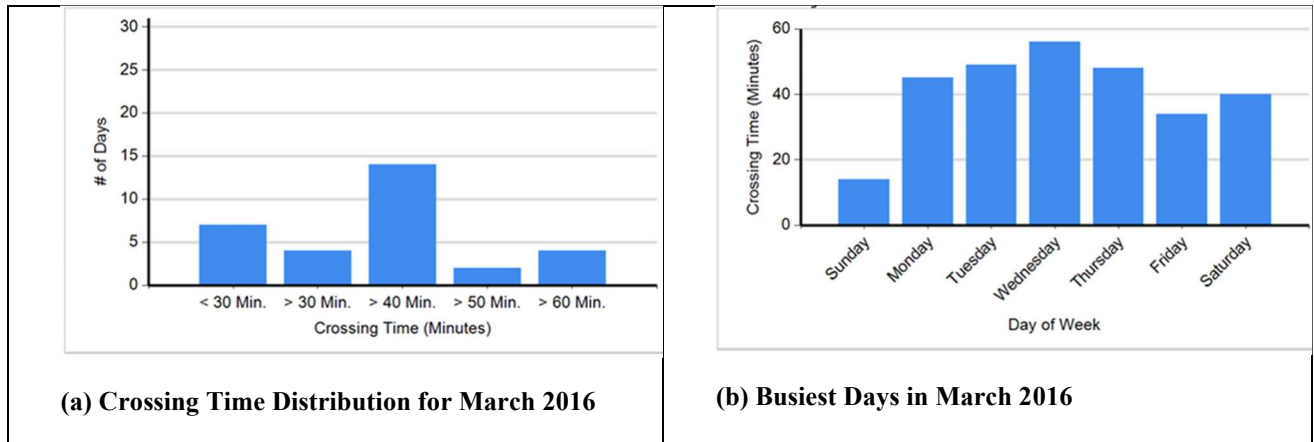

Figure 18: Example Data Visualization – Daily and Weekly Trends in Crossing Times at Zaragoza POE in El Paso, Texas (Source: BCIS)

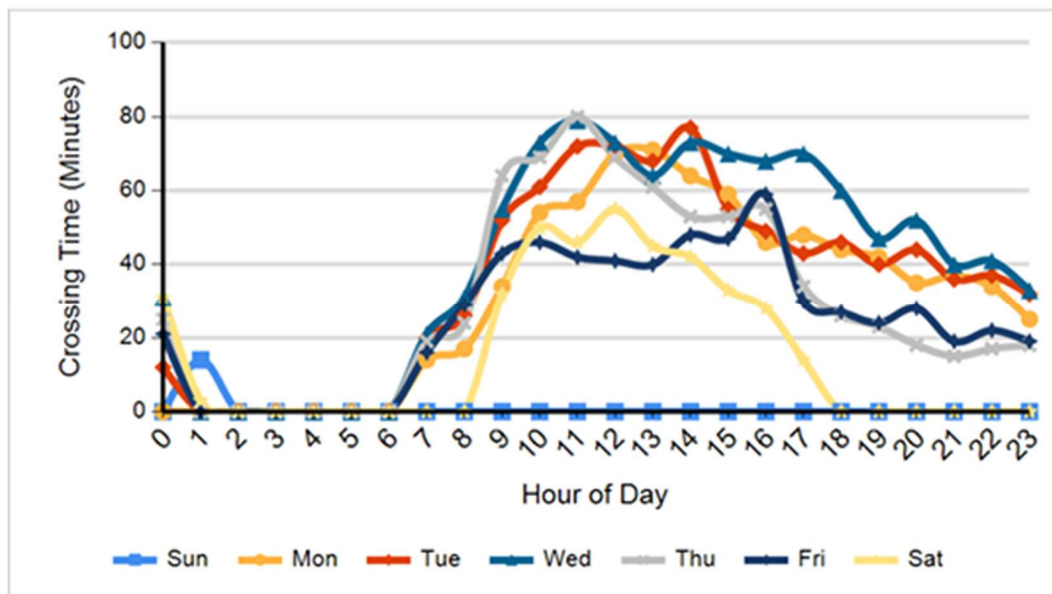

Figure 19: Example Data Visualization – Busiest Hours of the Day for a Given Month at Zaragoza POE in El Paso, Texas (Source: BCIS)

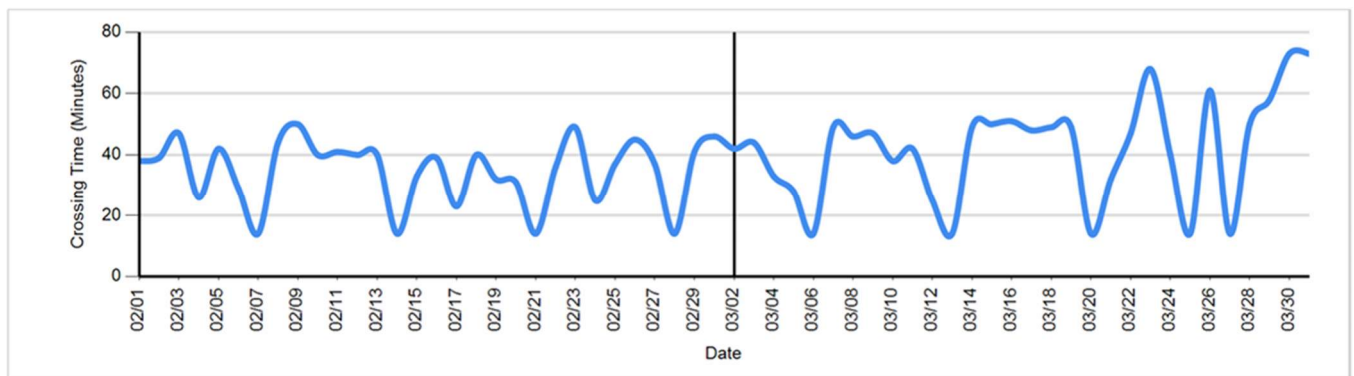

Figure 20: Example Data Visualization – Average Daily Crossing Times Compared to Previous Month

3.4 State of the Practice Review (and Case Studies)

3.4.1 State of the Practice at the U.S-Canada Border

Buffalo-Niagara Falls Region

In New York state, there are 17 land POEs spread across 445 miles of border with Canada. According to Bureau of Transportation Statistics (BTS), during 2023, over 14 million people and close to 8 million vehicles crossed southbound into the US through these land ports of entry. Despite the low Niagara Falls' population, the Buffalo-Niagara Falls Region stood out as the busiest area within the state due to its touristic destination, handling more than 60% of all crossings. The following are the POEs situated at the Buffalo-Niagara Falls region:

- **Lewiston Bridge:** Located at the north part of the region, the crossing permits pedestrians, passenger and commercial vehicles.
- **Peace Bridge:** It is located between downtown Buffalo, NY and Fort Erie, ON, making it the busiest crossing in the region. Pedestrians, bikes, and passenger and commercial vehicles can pass through.
- **Rainbow Bridge:** This crossing connects the cities of Niagara Falls, US and Niagara Falls, Canada. It allows pedestrians and passenger vehicles.
- **Whirlpool Bridge:** The bridge consists of two levels; the upper deck serves railway traffic, while the lower deck functions for passenger vehicles. This is a NEXUS only bridge, meaning that everyone in the car needs to be a NEXUS holder in order to cross. No commercial traffic is allowed.

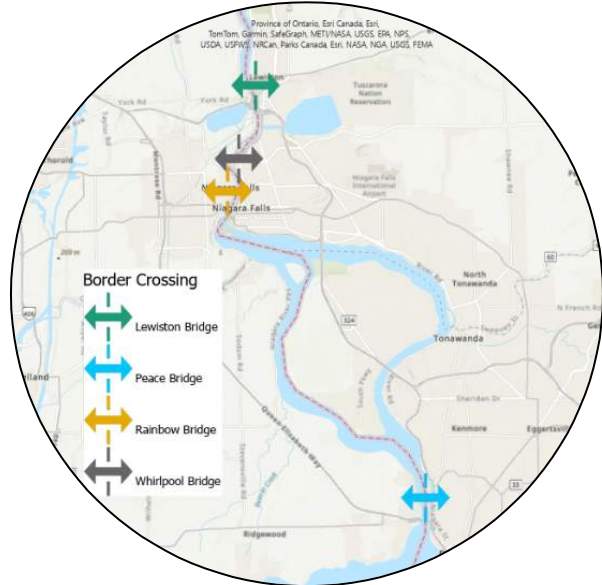

In 2013, a project to develop an automatic system to estimate border wait time at Peace Bridge was initiated. Bluetooth readers were deployed as part of the Bluetooth Traffic Monitoring System from TPA North America, supported by funding from Transport Canada and the FHWA. These readers anonymously collect travel data from Bluetooth and Wi-Fi enabled devices, tracking vehicles as they cross the border and providing valuable insights into border wait times and traffic patterns. The system also records metrics such as speed, travel time, and delay. Currently, this technology is available at other ports of entry in the area:

- Peace Bridge: Available for both Privately Owned Vehicles (POV) and Commercial Motor Vehicles (CMV).
- Lewiston Bridge: Available for both POV and CMV.
- Rainbow Bridge: Available for POV.

NITTEC and the Peace Bridge disseminate the border wait times at their respective web pages. In addition to the crossing times computed by the system, live cameras are available for commuters.

Detroit-Windsor Tunnel

The Detroit-Windsor Tunnel is an underwater international vehicular tunnel that connects Detroit, MI, to Windsor, Ontario. It facilitates cross-border travel for both passenger and commercial vehicles, as well as NEXUS holders in both directions. However, it does not have access for pedestrian.²⁵

Over time, there have been several attempts to implement a BWT system at the Detroit-Windsor Tunnel. For instance, in the early 2000s, a basic method was attempted, involving manual recognition of license plates. This data was collected manually and sent to CBP via email, where it was then matched with the time the vehicle crossed the primary inspection booth.²⁶

Ontario’s Ministry of Transportation began a project in 2014 to deploy loop detectors and Bluetooth readers on the streets leading up to the Ambassador Bridge and the Detroit-Windsor Tunnel to measure southbound travel times on the Canadian side.²⁷ This system reported crossing times through a website and by SMS text messages to enrolled users, and information was summarized and reported to border agencies. In 2016, a \$95,920 federal grant was awarded to a partnership between Michigan DOT and the Detroit-Windsor Tunnel to enhance this system, as part of the FHWA Border Wait Time Technology Deployment Initiative. The grant funded a pilot project to deploy new Bluetooth hardware and expand the geographic coverage of the system on the U.S. side for northbound traffic. The system was set up to collect and measure border wait times in “scalable geofenced areas” leading up to and from the tunnel, and to provide real-time traveler information to the public.²⁸ Although the Detroit-Windsor Tunnel website currently displays border crossing times in both the northbound and southbound directions, it also directs users to the border wait time web pages for U.S. CBP and CBSA, indicating that the pilot may have concluded, and that the system is no longer in operation; current wait times posted by CBP are not collected through an automated crossing wait time system.²⁹



3.4.2 State of the Practice at the U.S-Mexico Border

Systems to measure BWT currently deployed along the U.S.-Mexico border have many similar characteristics and all report their information through a common system, the Border Crossing Information System (BCIS), currently implemented and operated by TTI. The paragraphs that follow discuss the systems currently in place along the southern border states, including Texas, New Mexico, Arizona, and California. **Figure 21** shows these locations on a map.³⁰

²⁵ U.S. Customs and Border Protection. 2016. 2012-2016 Progress Report: Beyond the Border Action Plan.

<https://www.dhs.gov/sites/default/files/publications/btb%20report%20card%20-2012-2016%20%28update%202016%2012%29%20final.pdf>

²⁶ Sabean, J., and Jones, C. (2008). Inventory of Current Programs for Measuring Wait Times at Land Border Crossings. CBP, DHS, CBSA. <https://citeseerx.ist.psu.edu/document?repid=rep1&type=pdf&doi=a7d39309dbeb991b0c97263e6ff22d4e295cda70>

²⁷ <https://www.cbc.ca/news/canada/windsor/bluetooth-vehicle-tracking-could-soon-be-on-windsor-streets-1.2542012>

²⁸ https://www.ibtta.org/sites/default/files/documents/2016/Mexico/Belitsky_Neal.pdf

²⁹ <https://bwt.cbp.gov/details/03380002/COV>

³⁰ The BWT measurement systems in Arizona and New Mexico currently do not have a dedicated funding source and as a result, are currently not operational and are not shown on the BCIS website.

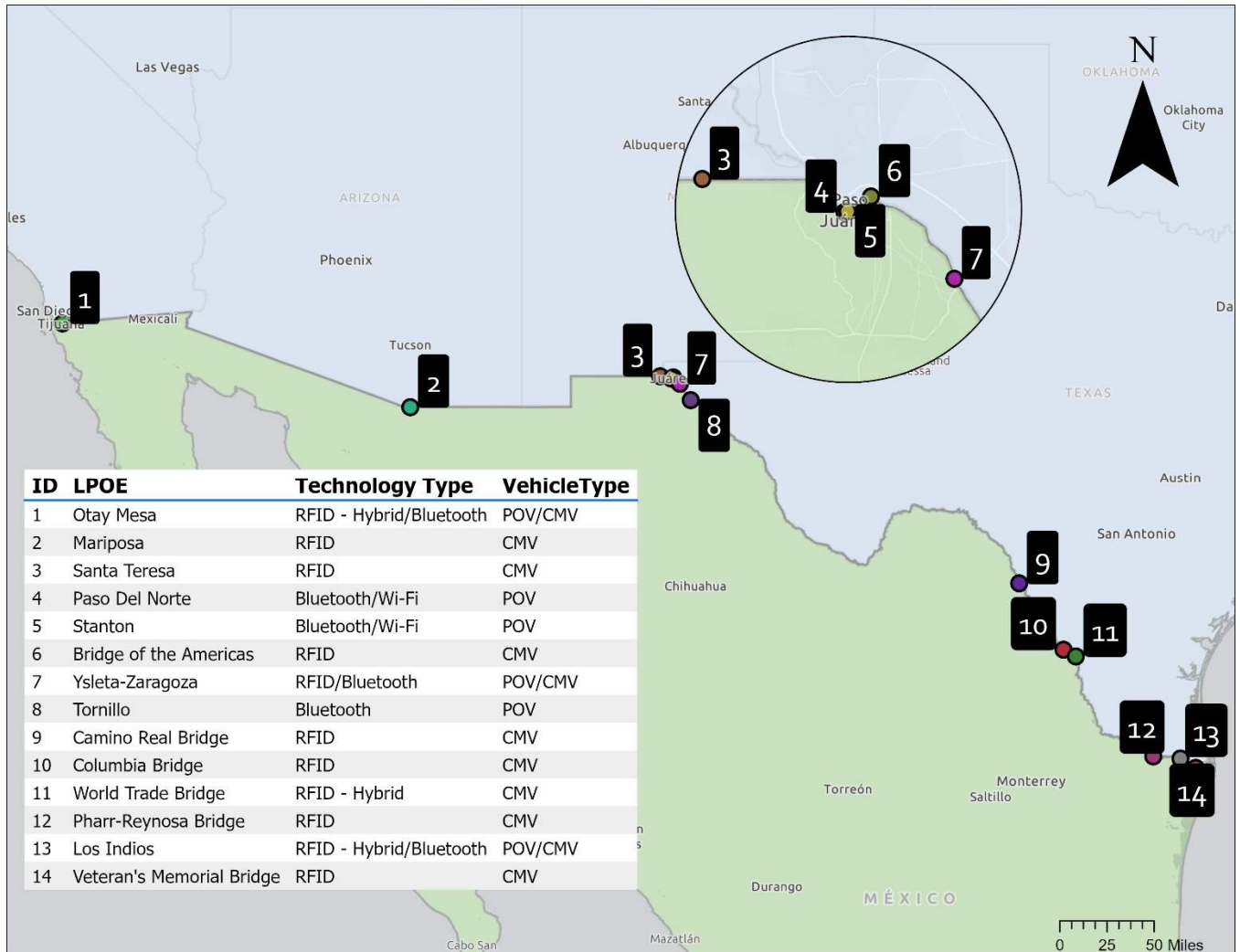

Figure 21: U.S.-Mexico Border Crossing Information System Locations

Texas-Mexico Border Crossings

Texas-Mexico Border Crossings: Existing Systems

The border between Texas and Mexico spans 1,254 miles and encompasses 28 international crossings. Of these, 25 crossings permit a mix of commercial, personal vehicle, and/or pedestrian traffic. The remaining three crossings consist of two dams and a ferry. The Texas border is adjacent to the Mexican states of Tamaulipas, Nuevo Leon, Coahuila, and Chihuahua.

At eight Texas border crossings, BWT for commercial vehicles are tracked using an RFID-based re-identification system. This system is engineered to read RFID tags (including those utilized by CBP programs and toll tags) with the help of two RFID readers installed on the Mexican side of the border and two more on the U.S. side. These RFID readers were strategically placed to capture the average end of the queue during peak crossing times. The BWT for commercial vehicle crossings is calculated based on the travel time from the RFID station at the Mexican toll booth exit to the RFID station at the U.S. CBP primary inspection booth exit at each crossing. The border crossing time for commercial vehicles is estimated from the travel time

between a point upstream of the queue, before the queue starts forming, and the exit of either the Federal compound or the Texas Border Safety Inspection Facility.

Currently, BWT measurement systems for passenger vehicles are deployed at only four border crossings, three in the El Paso region and one in the Rio Grande Valley region. These include the Zaragoza/Ysleta crossing, the Paso Del Norte and the Stanton Street Bridges in El Paso, and the Free Trade International Bridge in Los Indios.

Information for all the Texas BWT systems is disseminated via the BCIS website (see **Figure 22**). In addition, TTI developed a dashboard specifically for commercial vehicles to communicate border delays and their economic impacts. The data source for the delay measures includes an RFID-based system to gather raw crossing times. This data enables the breakdown of commercial BWT by FAST and non-FAST lane. These systems continuously provide crossing time data from northbound trucks equipped with transponders issued by various agencies, such as U.S. CBP and tolling agencies. The data from the RFID systems are stored in a centralized data warehouse where truck crossing times are aggregated into different temporal granularities and converted into various performance measures.

Border Crossing Information System

English (United States) ▼

Real-time Information Archived Data Project Reports About Team and Sponsors Help and Glossary Contact Us

Real-time Information

Commercial Vehicles

Crossing Name	Expected Wait Time in Minutes		Expected Crossing Time in Minutes		Updated at
	FAST	Non-FAST	FAST	Non-FAST	
Veteran's Memorial Bridge, Brownsville, TX	No Delay	67	20	78	2/12/2024 4:20:00 PM
Pharr-Reynosa International Bridge, Pharr, TX	N/A	N/A	N/A	N/A	2/12/2024 4:20:00 PM
World Trade Bridge, Laredo, TX	N/A	N/A	N/A	N/A	2/12/2024 4:20:00 PM
Colombia Bridge, Laredo, TX	No Delay	63	66	125	2/12/2024 4:20:00 PM
Camino Real International Bridge, Eagle Pass, TX	N/A	No Delay	N/A	13	2/12/2024 4:20:00 PM
Ysleta-Zaragoza Bridge, El Paso, TX	91	51	161	124	2/12/2024 3:20:00 PM
Free Trade International Bridge, Los Indios, TX	No Delay	No Delay	108	64	2/12/2024 4:20:00 PM
Bridge of the Americas, El Paso, TX	Closed	Closed	Closed	Closed	2/12/2024 3:20:00 PM
Otay Mesa Crossing, San Diego, CA	12	15	29	31	2/12/2024 2:20:00 PM



© 2024 - Texas A&M Transportation Institute, The Texas A&M University System, 3135 TAMU, College Station, TX 77843-3135

Border Crossing Information System

English (United States) ▼

Real-time Information Archived Data Project Reports About Team and Sponsors Help and Glossary Contact Us

Real-time Information

Passenger Vehicles

Crossing Name	Expected Wait Time in Minutes		Updated at
	Southbound	Northbound	
Paso del Norte Bridge, El Paso, TX	N/A	245	2/12/2024 3:20:00 PM
Stanton Street Bridge, El Paso, TX	No Delay	N/A	2/12/2024 3:20:00 PM
Stanton Street DCL Bridge, El Paso, TX	N/A	No Delay	2/12/2024 3:20:00 PM
Ysleta-Zaragoza Bridge, El Paso, TX	13	14	2/12/2024 3:20:00 PM
Free Trade International Bridge, Los Indios, TX	N/A	54	2/12/2024 4:20:00 PM
Marcelino Serna, Tornillo, TX	No Delay	No Delay	2/12/2024 3:20:00 PM



© 2024 - Texas A&M Transportation Institute, The Texas A&M University System, 3135 TAMU, College Station, TX 77843-3135

Figure 22. U.S.-Mexico Border Crossing Information System Website ^{31 32}

³¹ <https://bcis.tti.tamu.edu>

³² N/A can indicate either the lane type is not available at that crossing or the system is under-maintenance. The above figure, the systems at World Trade Bridge and Pharr Reynosa were under maintenance when the screenshot was taken. The Camino Real international bridge does not have FAST lanes. Paso del Norte passenger crossing, Stanton Street DCL and Free Trade International Bridge only offer northbound passenger lanes. Whereas the Stanton Street Bridge only offers Southbound passenger lanes.

The subsequent paragraphs offer a description of each border crossing included in the BCIS and the technologies deployed at each location in Texas. A summary is also provided in **Table** .

- **Veterans Memorial Bridge, Brownsville:** This border crossing is a 4-lane bridge that links U.S. Highway 77 in Brownsville, Texas to Matamoros, Mexico via Boulevard Luis Donaldo Colosio, which extends to Ciudad Victoria and Reynosa. This crossing features FAST lanes in both directions and a dedicated commuter lane using SENTRI. Currently, RFID technology is employed at this crossing for measuring commercial vehicle BWT.
- **Pharr-Reynosa International Bridge, Pharr:** This bridge, which has four lanes (three northbound and one southbound), links Highway 281 in Pharr, Texas to Mexico’s Highway 2 and the City of Reynosa, Tamaulipas. It features FAST lanes and uses RFID technology to measure BWT for commercial vehicles.
- **World Trade Bridge, Laredo:** This commercial bridge spans the Rio Grande River, connecting the cities of Laredo, Texas and Nuevo Laredo, Tamaulipas in Mexico. Owned and operated by the City of Laredo and Mexico’s federal Secretariat of Communication and Transportation, it is the largest POE in the U.S. by both volume and value. The bridge, which can be accessed via I-35 in Laredo and Highway 2 in Mexico, uses RFID technology to measure BWT for commercial vehicles.
- **Colombia-Solidarity Bridge, Laredo:** This eight-lane bridge with pedestrian walkways connects Laredo, Texas over the Rio Grande river with Colombia in Anahuac, Nuevo Leon in Mexico. Owned and operated by the City of Laredo and the Secretaria de Comunicaciones y Transportes, this tolled crossing is open to personal and commercial vehicles (except on Sunday for commercial vehicles). It connects to Texas State Highway 255 (a toll road) and Interstate 35 on the U.S. side, and to the Nuevo Leon State Highway 1 Spur and Highway 1 proper on the Mexico side. It features FAST lanes and uses RFID technology to measure BWT for commercial vehicles.
- **Camino Real International Bridge, Eagle Pass:** This six-lane bridge (three lanes in each direction) with two pedestrian walkways connects Highway 480 in Eagle Pass, Texas over the Rio Grande to Piedras Negras, Coahuila and Mexico’s super highway that extends to Mexico City. Open to personal and commercial vehicles, it uses RFID technology to measure BWT for commercial vehicles.
- **Free Trade International Bridge, Los Indios, TX:** This border crossing crosses connects the U.S.-Mexico border cities of Los Indios, Texas and Matamoros, Tamaulipas. Owned and managed by Cameron County on the U.S. side and operated by Compania Operadora de Puentes y Autopistas on the Mexican side, it is open to both passenger vehicles and commercial trucks. The bridge is four lanes wide (two northbound and two southbound). On the U.S. side, it connects with Cantu Road and on the Mexican side, it connects with the Reynosa Matamoros Highway. This bridge uses RFID technology to measure BWT for commercial vehicles, and Bluetooth/Wi-Fi to measure the BWT of passenger vehicles.
- **Zaragoza (Ysleta) Bridge, El Paso:** This border crossing, owned and operated by the City of El Paso on the U.S. side and by the Fideicomiso de Puentes Internacionales of the State of Chihuahua (Fideicomiso Chihuahua) on the Mexico side, connects El Paso, Texas with Ciudad Juarez, Chihuahua in Mexico. It consists of two bridges, one for passenger vehicles and pedestrians and the other for commercial vehicles. The passenger vehicle bridge has two northbound lanes, two southbound lanes, and one commuter traffic lane. The commercial bridge has two lanes in each direction, one of which is a designated FAST lane. RFID technology is used to measure BWT for commercial vehicles, while Bluetooth readers are installed northbound and southbound to measure BWT for passenger vehicles.

- **Bridge of the Americas, El Paso:** This toll-free crossing, owned by the U.S.-Mexico International Boundary and Water Commission (IBWC), connects El Paso, Texas and Ciudad Juarez, Mexico. It consists of a northbound structure and a southbound structure. Passenger vehicles use Boulevard Ing. Bernardo Norzagaray and Avenida Abraham Lincoln in Mexico and I-110, Highway 54, and I-10 in Texas, while commercial vehicles access the crossing from Cuatro Siglos Street and Highway 45 in Mexico and Gateway Boulevard and Highway 54 in Texas. It features FAST lanes and uses RFID technology to measure BWT for commercial vehicles.
- **Paso Del Norte Bridge, El Paso:** This border crossing, which is exclusively for passenger vehicles and pedestrians, connects El Paso, Texas and Ciudad Juarez, Chihuahua in Mexico. It is owned and operated by the City of El Paso on the U.S. side and the Fideicomiso Chihuahua on the Mexico side, similar to the Zaragoza (Ysleta) Bridge. The crossing comprises a single bridge with four lanes for passenger vehicle traffic, all of which are northbound. One of these lanes is a dedicated SENTRI commuter lane, while the other two serve Ready and Standard Lane traffic. Wi-Fi readers have been installed at this location to measure BWT in both directions.
- **Stanton Bridge, El Paso:** This border crossing, also exclusively for passenger vehicles and pedestrians, links El Paso, Texas with Ciudad Juarez, Chihuahua. It works partly as the southbound counterpart for the Paso Del Norte Bridge in Mexico. Like the Paso Del Norte Bridge, it is owned and operated by the City of El Paso on the U.S. side and the Fideicomiso Chihuahua on the Mexico side. The crossing consists of a single bridge for passenger vehicles and pedestrians, with three lanes for southbound passenger vehicles and one dedicated SENTRI lane for northbound vehicles. Wi-Fi readers have been installed at this location to measure BWT for southbound passenger vehicle traffic and northbound SENTRI lane traffic.

Table 3. Border Crossings in Texas with BCIS

POE	Location		Vehicles Served		Direction		Tech. Deployed
	US	MX	POV	CMV	NB	SB	
Veterans Memorial Bridge	Brownsville, TX (U.S. Highway 77)	Matamoros, Tamaulipas (Blvd Luis Donaldo Colossio)	Yes SENTRI	Yes FAST	Yes	Yes	RFID
Pharr-Reynosa International Bridge	Pharr, TX (Highway 281)	Reynosa, Tamaulipas (Mexico's Highway 2)	Yes General	Yes FAST	Yes	Yes	RFID
World Trade Bridge	Laredo, TX (I-35)	Nuevo Laredo, Tamaulipas (Mexico's Highway 2)	No	Yes FAST	Yes	Yes	RFID
Colombia-Solidarity Bridge	Laredo (Texas State Highway 255 & I-35)	Anahuac, Nuevo Leon (State Highway 1 Spur and Highway 1)	Yes General	Yes FAST	Yes	Yes	RFID

POE	Location		Vehicles Served		Direction		Tech. Deployed
	US	MX	POV	CMV	NB	SB	
Camino Real International Bridge	Eagle Pass (Highway 480)	Piedras Negras, Coahuila (Mexico's Super Highway)	Yes General	Yes FAST	Yes	Yes	RFID
Free Trade International Bridge	Los Indios (Cantu Road)	Matamoros, Tamaulipas (Reynosa Matamoros Highway)	Yes General	Yes FAST	Yes	Yes	RFID (Hybrid) & Bluetooth
Zaragoza (Ysleta)	El Paso (Zaragoza Road)	Ciudad Juarez, Chihuahua (Av. Waterfill)	Yes SENTRI	Yes FAST	Yes	Yes	RFID & Bluetooth
Bridge of the Americas	El Paso (US 54)	Ciudad Juarez, Chihuahua (Mexico's Highway 45)	Yes General	Yes FAST	Yes	Yes	RFID
Paso Del Norte	El Paso (El Paso Street)	Ciudad Juarez, Chihuahua (Av. Benito Juarez)	Yes General	No	Yes	No	Bluetooth-Wi-Fi
Stanton	El Paso (9th Ave)	Ciudad Juarez, Chihuahua (Av. Lerdo)	Yes SENTRI	No	Yes	Yes	Bluetooth-Wi-Fi

Texas-Mexico Border Systems: TxDOT BCIS Expansion Plan

TxDOT, with the assistance of TTI, is currently conducting an ambitious project to update and expand the BCIS at various commercial and passenger vehicle border crossings. The first phase of the project involves the operation, maintenance, and potential enhancement of BCIS at existing border crossings. This is followed by an upgrade of the RFID readers for the Decal and Transponder Online Procurement System (DTOPS) at seven existing reading stations across the Texas-Mexico border.³³ The upgrade process includes coordination with CBP's contractor (CueBid) and the RFID reader manufacturer, configuration and testing of each reader, and replacement and testing of the RFID system once reinstalled.

The project then moved into its expansion phase, with the Border Wait Time Measurement System (BWTMS) being extended to the six additional commercial vehicle crossings listed below. This involves site visits, permit acquisition, equipment procurement, system installation and testing, and modification of the website and algorithm to include the new sites.

- Del Rio, Del Rio-Cd. Acuna International Bridge
- Progreso International Bridge

³³ The U.S. CBP DTOPS is designed to handle all RFID protocols and is used to collect raw crossing times. The data collected allows for the breakdown of commercial BWT by FAST and non-FAST lane. This information is then stored and can be accessed by the U.S. CBP and other relevant agencies. For more information please see: <https://dtops.cbp.dhs.gov/main/>

- Rio Grande City, Rio Grande Camargo Bridge
- Presidio, Presidio/Ojinaga International Bridge
- Roma, Roma International Bridge

The final phase of the project focuses on the expansion of the BCIS for 22 additional passenger vehicle border crossings over three fiscal years. This involves site visits, permit acquisition, equipment procurement, system installation and testing, and modification of the website and algorithm to include the new sites. This comprehensive project aims to enhance the efficiency and effectiveness of border crossings between Texas and Mexico.

Texas-Mexico Border Systems: El Paso ITS Ports of Entry Project

El Paso was one of the first deployments of the BCIS, with the first RFID-based systems being tested and deployed prior to 2010, and the first passenger vehicle Bluetooth systems being deployed shortly after. Additionally, since 2006, El Paso has been a test-bed for border wait time measurement technology through the collaboration of federal, state and local stakeholders with TTI. El Paso is currently the site with the most comprehensive BWT system on the Texas-Mexico border.

The City of El Paso is currently spearheading the ITS Ports of Entry Project, a multiagency, bi-national initiative aimed at enhancing the operations of the four international bridges within the city. These bridges include the Bridge of the Americas, the Ysleta-Zaragoza Bridge, the Stanton Street Bridge, and the Paso Del Norte Bridge. The project's primary goal is to improve various aspects of the border crossings, including traffic operations, security, user empowerment, bi-national collaboration, customer satisfaction, safety, efficiency, and bridge-crossing reliability. The project is currently underway as a collaborative effort involving multiple stakeholders and regional partners. These include the City of El Paso International Bridges Department, TxDOT, U.S. CBP, IBWC, and TTI, among others.¹⁸

The project allocates \$32 million for the construction, acquisition, and installation of an ITS at the Bridge of the Americas and Ysleta-Zaragoza Bridges border crossings. These funds will be used both within the right-of-way of TxDOT, and within City of El Paso-owned roadways.³⁴In addition to this, the project encompasses planned ITS and roadway projects at all four border crossings. Key elements of the project include:

- The expansion of the BCIS commercial vehicle BWT RFID systems at the Bridge of the Americas and Ysleta-Zaragoza Bridges border crossings.
 - Expansion of northbound systems from their original footprint (2008), which no longer reflects current traffic queuing patterns.
 - Deployment of a southbound RFID-based system at both crossings.
 - Deployment of LiDAR real-time volume counters for the southbound direction.
- The expansion of the BCIS passenger vehicle BWT system at the Bridge of the Americas and Ysleta-Zaragoza Bridge border crossings.
 - Expansion of Ysleta-Zaragoza Bluetooth/Wi-Fi system from its original footprint (2012), which no longer reflects current traffic queueing patterns.
 - Deployment of a northbound at the Bridge of the Americas and a southbound Bluetooth/Wi-Fi-based system at both crossings

¹⁸ City of El Paso (2019). *El Paso Intelligent Transportation System Ports of Entry Concept of Operations*. City of El Paso, El Paso, TX.

- Deployment of LiDAR real-time volume counters for the northbound and southbound direction at Bridge of the Americas, and for the southbound direction at the Ysleta-Zaragoza bridge.
- The deployment of dedicated DMS along the El Paso region’s main corridors leading to the border crossings to provide the driving public with real-time border crossing times at all border crossing options in the region.
- The deployment of additional CCTV cameras in key locations at both the Bridge of the Americas and Ysleta-Zaragoza Bridge border crossings.
- The construction of a dedicated Border Traffic Management Center at the Ysleta-Zaragoza border crossing to house the City of El Paso ITS project.

As part of this process, a Concept of Operations (ConOps) document was developed to serve as a roadmap for the proposed ITS, detailing high-level user needs and system capabilities. The document also includes a comprehensive analysis of the existing conditions, constraints, challenges, and opportunities at the four POEs, and outlines operational scenarios, performance management strategies, and next steps for the project. **Figure 23** presents the project concept. The implementation of the project is currently underway.

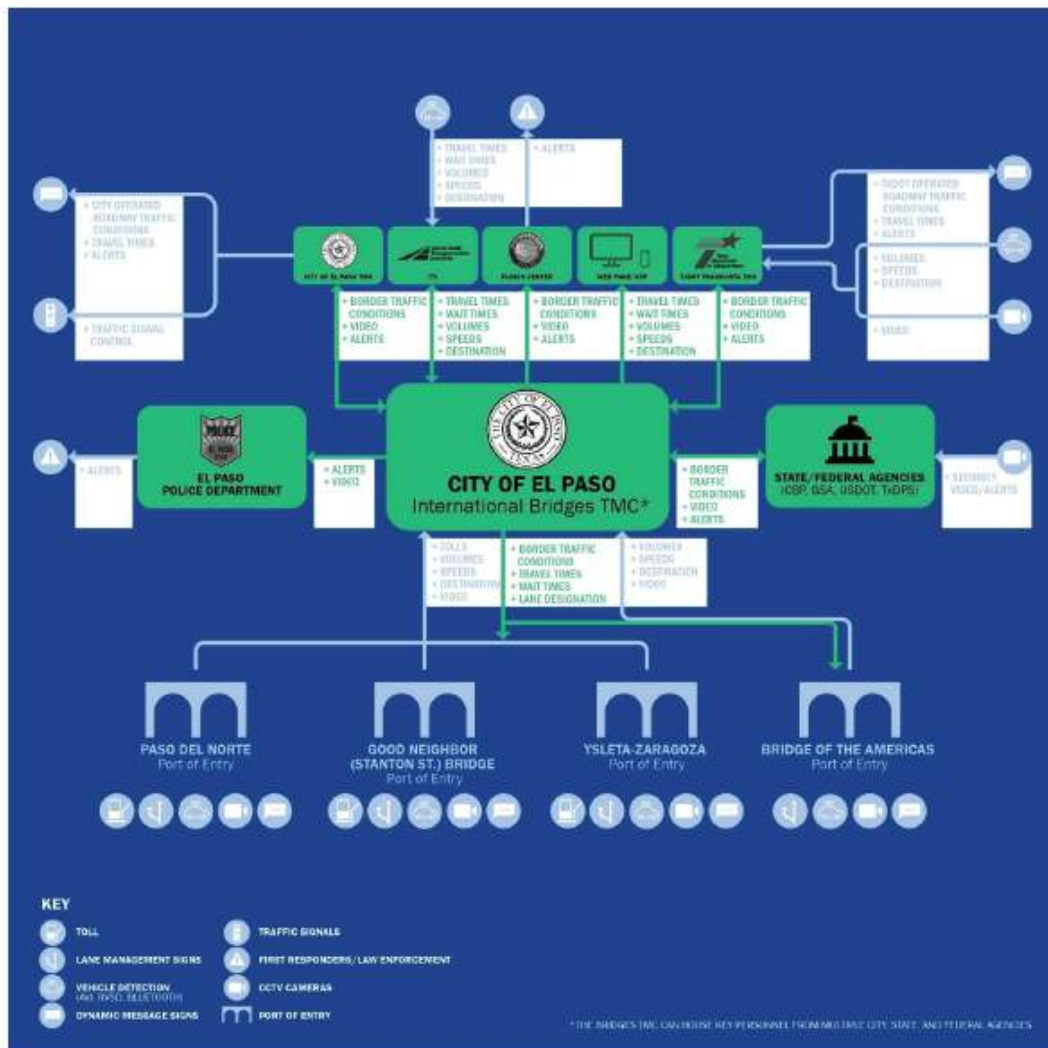

Figure 23. El Paso ITS Ports of Entry Project Concept (Source: City of El Paso)

New Mexico-Mexico Border Crossings

New Mexico shares a 180-mile border with Mexico. There are three ports of entry along this 180-mile border, viz., Antelope Wells, Columbus and Santa Teresa. Antelope Wells is the smallest POE and only offers passenger vehicle crossings. Columbus and Santa Teresa ports of entry offer both passenger as well as commercial vehicle crossings.

The Santa Teresa northbound commercial crossing offers FAST, Standard, as well as oversized options for commercial vehicles. The Santa Teresa POE is equipped with RFID readers for the measurement of northbound commercial vehicle border crossing times. The northbound commercial wait times are available to CBP through an API offered by BCIS and the wait times as well as crossing times are made available to the travelling public through the BCIS web interface. The system has been temporarily out of service due to maintenance at the crossing since 2022.

Arizona-Mexico Border Crossings

Arizona has 9 land entry points along its 372-mile border with Mexico. The most significant commercial and passenger vehicle crossings are located in Nogales. There are three border crossing facilities in or near the cities of Nogales, AZ, and Nogales, Sonora, MX, which are along the southern boundary of Arizona and the northern frontier of Sonora, Mexico. These three crossings include:

- The Nogales-Mariposa Crossing: Located at Mariposa Rd., it serves both trucks and cars via SR189 in AZ and Fed. 15 in Mexico. It's the only truck crossing in the Nogales area.
- The Nogales-Grand Avenue Crossing (also known as the Nogales – DeConcini crossing): It serves only cars via Interstate 19 in AZ and Boulevard Adolfo Lopez Mateos in Mexico.
- The Nogales-Morley Gate Crossing: Located at Morley Avenue, it serves pedestrians exclusively.

In 2015, ADOT's RFID-based BWT system started operations at the Nogales – Mariposa crossing to measure commercial vehicle wait times. This system uses RFID tags already required by ADOT at state inspection facilities and by trucks enrolled in the FAST program. The system has four readers, the first at the ANAM (Mexican Customs) facility, 8 miles from the border, the second near the expected end of the queue, about 0.5 miles south of the U.S. CBP Primary Inspection booths, the third at the CBP Primary Inspection booths, and the last at the exit of the ADOT rapid commercial vehicle inspection lanes. The BWT data generated by the system is processed and reported as wait time using TTI's BCIS. The system has been temporarily out of service due to maintenance at the crossing since 2021.

California-Mexico Border Crossings

There are seven ports of entry along the California-Mexico border. Out of the seven crossings, BWT measurement systems have been deployed by Caltrans and SANDAG at the following crossings:

- **Otay Mesa Passenger Northbound Crossing.** This crossing permits passenger vehicle and pedestrians to cross from Mexico into the United States. For passenger vehicles this crossing offers the options to use the Ready, SENTRI, or the Standard lanes. The three types of lanes have separate approaches leading from roadways in Mexico to the border crossing. The crossing remains open 24 hours a day to accommodate passenger vehicles and pedestrians. It provides 13 lanes for vehicle processing and 12 toll booths for pedestrians. The passenger vehicle crossing times at this crossing are measured using Bluetooth/Wi-Fi technologies and are available on the Caltrans Quickmaps website and mobile application (<https://quickmap.dot.ca.gov>).

- **Otay Mesa Passenger Southbound Crossing.** This crossing permits passenger vehicle and pedestrians to cross from United States into Mexico. There is only one approach leading from roadways in United States to the border crossing. It has 5 lanes for passenger vehicles to cross into Mexico while the facility remains open 24 hours a day. The passenger vehicle crossing times at this crossing are measured using Bluetooth/Wi-Fi technologies and are available on the Caltrans Quickmaps website and mobile application (<https://quickmap.dot.ca.gov>).
- **Otay Mesa Commercial Northbound Crossing.** This crossing permits commercial vehicles to cross from Mexico into the United States. The crossing features dedicated lanes for Empty Vehicles, FAST eligible vehicles, and Standard vehicles. This crossing also offers Unified Cargo Processing lanes program, through which the United States Customs and Mexican Customs agencies perform vehicle and cargo inspection simultaneously at the same location for expedited inspection. The border crossing operates on weekdays from 6 am to 8 pm, remaining closed on weekends. It includes 16 lanes dedicated to processing commercial traffic. The border wait time and crossing time at this crossing is measured using a hybrid system, which consists of a combination of Bluetooth, Wi-Fi, and RFID readers, which read commercial vehicle transponders. The wait times and crossing times at this crossing are published on the BCIS and also made available to the CBP BWT systems using an interface.

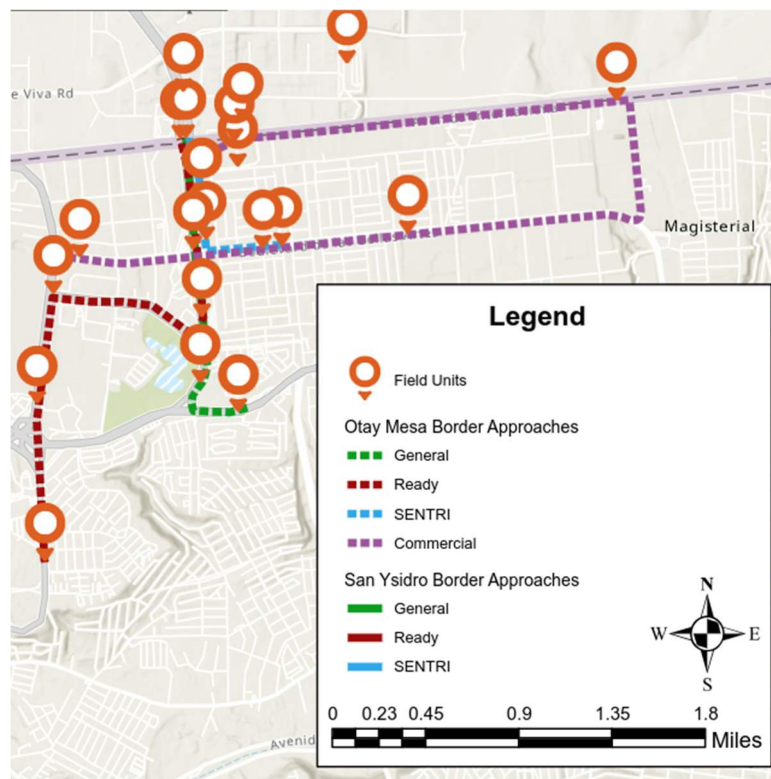

Figure 24: Otay Mesa Northbound Passenger Crossing Lane Configuration (Source: IBI/TTI)

- **Otay Mesa East Border Crossing Project.** The Otay Mesa East border crossing project, upon completion will link State Route 11 in San Diego, California, to Boulevard Las Torres in Tijuana, Mexico. Designed to enhance the border crossing experience for both personal and commercial vehicles, the crossing will feature a total of 20 lanes—split evenly between personal and commercial use. A notable aspect of this project is the implementation of a toll fee, strategically set to achieve an

average crossing time of 20 minutes. Currently in the design and construction phase, the crossing is anticipated to be operational by the end of 2024. According Caltrans and SANDAG, the goal is to have an ITS border wait time system deployed through a partnership with the Otay Mesa Chamber of Commerce. The BWT system will be designed to provide real-time updates on crossing times for both northbound and southbound traffic. Equipped with a network of sensors extending over a 6-mile stretch along the queue, the system aims to offer accurate and timely information to commuters. This data will be accessible via a free application and displayed on traveler information systems, enhancing the convenience for users by also including details on toll rates, special lane conditions, and regional POE incidents.^{35 36}

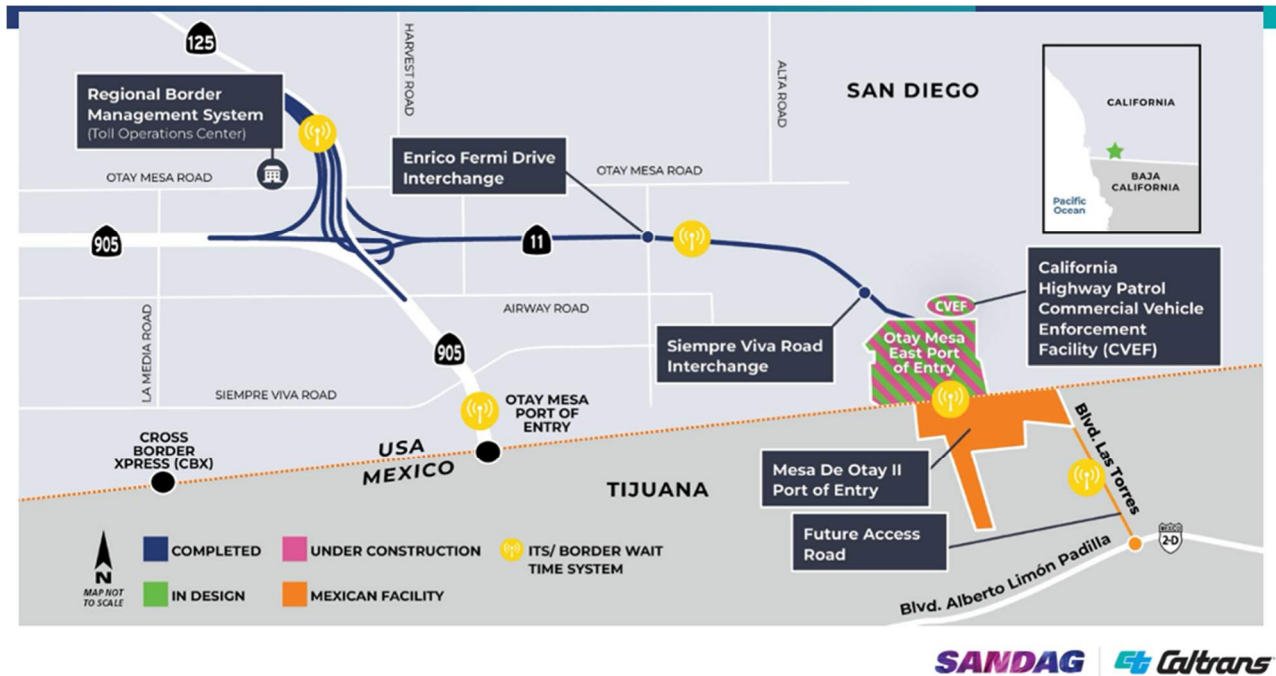

Figure 25: Otay Mesa East Border Crossing Project (Source: Caltrans and SANDAG)

- **San Ysidro Passenger Northbound Crossing.** This crossing permits passenger vehicle and pedestrians to cross from Mexico into the United States. For passenger vehicles this crossing offers the options to use the Ready, SENTRI, or the Standard lanes. The three types of lanes have separate approaches leading from roadways in Mexico to the border crossing. San Ysidro operates 24 hours a day to process vehicles and from 6 am to 2 pm for pedestrians, offering 34 lanes for vehicle inspections and an additional 12 lanes for pedestrians. The passenger vehicle crossing times at this crossing are measured using Bluetooth/Wi-Fi technologies and are available on the Caltrans Quickmaps website and mobile application (<https://quickmap.dot.ca.gov>).
- **San Ysidro Passenger Southbound Crossing.** This crossing permits passenger vehicle and pedestrians to cross from United States into Mexico. There are two distinct approaches leading from

³⁵ <https://insider.govtech.com/california/news/how-long-is-the-border-traffic-wait-there-ll-soon-be-an-app-for-that>

³⁶ Despite attempts to gather more detailed information about the BWT system's specific sensor and communications technology, responses from Caltrans and SANDAG were not available at the time of this report. The lack of detailed publicly available information on the BWT system likely reflects the project is still at an early stage in its design and construction phases, and decisions on BWT technology choices remain pending.

roadways in United States to the border crossing. Similar to the northbound schedule, it allows vehicles to cross southbound at any time of the day whereas for pedestrians from 3 pm to 11 pm. The vehicle crossing counts with 22 lanes. The passenger vehicle crossing times at this crossing are measured using Bluetooth/Wi-Fi technologies and are available on the Caltrans Quickmaps website and mobile application (<https://quickmap.dot.ca.gov>).

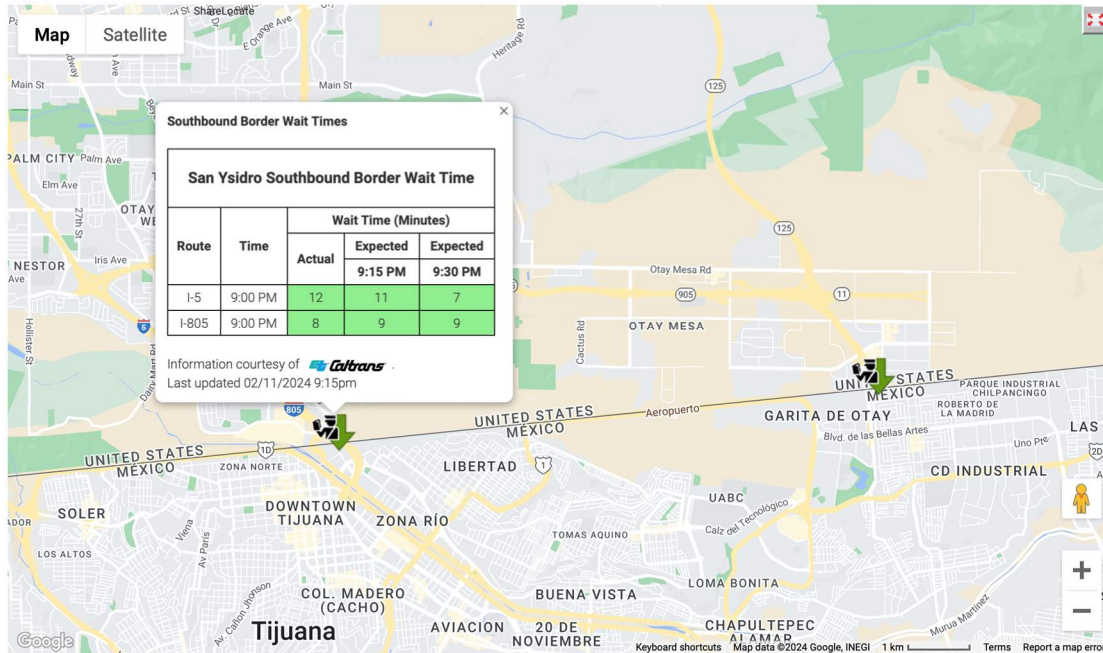

Figure 26. Caltrans Quickmaps Website

Assessment of Experience with BWT Measurement Technologies at the Southern Border

In evaluating the experience, feedback, and effectiveness of RFID, Bluetooth/Wi-Fi, and other technologies utilized across the southern border for BWT measurement systems, insights from TTI, the system's designer, integrator, and operator, are informative. TTI has expressed satisfaction with the performance and accuracy of RFID technology for commercial vehicles and Bluetooth/Wi-Fi systems for passenger vehicle applications. LiDAR technology in particular has demonstrated superior precision in real-time vehicle counts to other commercially available vehicle counting technology and has a very favorable cost-benefit ratio in terms of installation and maintenance. Importantly, the maintenance of Bluetooth/Wi-Fi systems has been identified as less burdensome compared to RFID systems. The ongoing preference for RFID and Bluetooth/Wi-Fi technologies in new deployments at the southern border underscores their technical reliability and effectiveness.

The development of hybrid systems that merge RFID with Bluetooth/Wi-Fi for commercial traffic, specifically at the Otay Mesa, Los Indios, and World Trade Bridge border crossings, was initiated to curb the infrastructure and equipment expenses associated with exclusive RFID setups. The long-term accuracy and performance of these hybrid systems are still being evaluated.

As for future technologies, TTI's pilot testing of camera-based detection, employing AI for image recognition, has shown significant promise, particularly in terms of accuracy and potential reductions in infrastructure costs. However, the transition to major deployments of this technology is pending, as pilot testing continues to assess its integration into the existing BWT measurement framework comprehensively.

3.5 Conclusion

A crucial insight from the deployment of BWT measurement systems along the U.S.- Mexico border emphasizes the importance of evaluating the penetration rates of various technologies at each POE and recognizing that these rates can change over time. For instance, a study by TTI in 2015, which examined Bluetooth device penetration rates in passenger vehicles at five border crossings, revealed that Bluetooth's effectiveness is influenced by user behavior, device usage, and the physical layout of the crossing facilities. The study concluded that only the Gateway to the Americas Bridge in Laredo demonstrated penetration rates consistently over 10 percent, making it suitable for a Bluetooth-based wait time measurement.³⁷ However, by 2022, Bluetooth penetration rates had notably increased across most Texas border crossings, leading to the successful implementation of a Bluetooth-based BWT system at the Los Indios, Texas crossing. The study also observed that at certain locations, Wi-Fi penetration exceeded that of Bluetooth, and with the growing ubiquity of RFID tags (i.e., toll tags, which are planned for the new Otay Mesa East border crossing that is currently under construction, and which are used at nearly all of the bridge crossings between Texas and Mexico with the exception of the Bridge of the Americas) on passenger vehicles, RFID technology has emerged as a feasible option at other crossings, as demonstrated by a TTI pilot project at the Paso Del Norte Bridge in El Paso.

Furthermore, the operational setup of many re-identification BWT systems suggests that selecting a technology for a location with an existing anti-idling system, such as the Canadian side of the Peace Arch crossing, would be practical. The well-defined staging area at the border process allows for the straightforward deployment of readers at the staging area's entry and exit points. Adjustments to the travel time measurement algorithms would then be required to account for this as an additional leg of the journey.

Additionally, **Figure 27** offers a visual comparison of the technology deployments at major crossings, highlighting both the differences and similarities between the Northern and Southern borders. This comparative analysis underscores the adaptability and tailored application of technology to meet the specific needs of each border crossing, ensuring efficient and accurate BWT measurement.

³⁷ *Analysis of Bluetooth Technology to Measure Wait Times of Passenger Vehicles at International Border Crossings, Final Report, Texas Department of Transportation, Texas A&M Transportation Institute, June 10, 2015.*

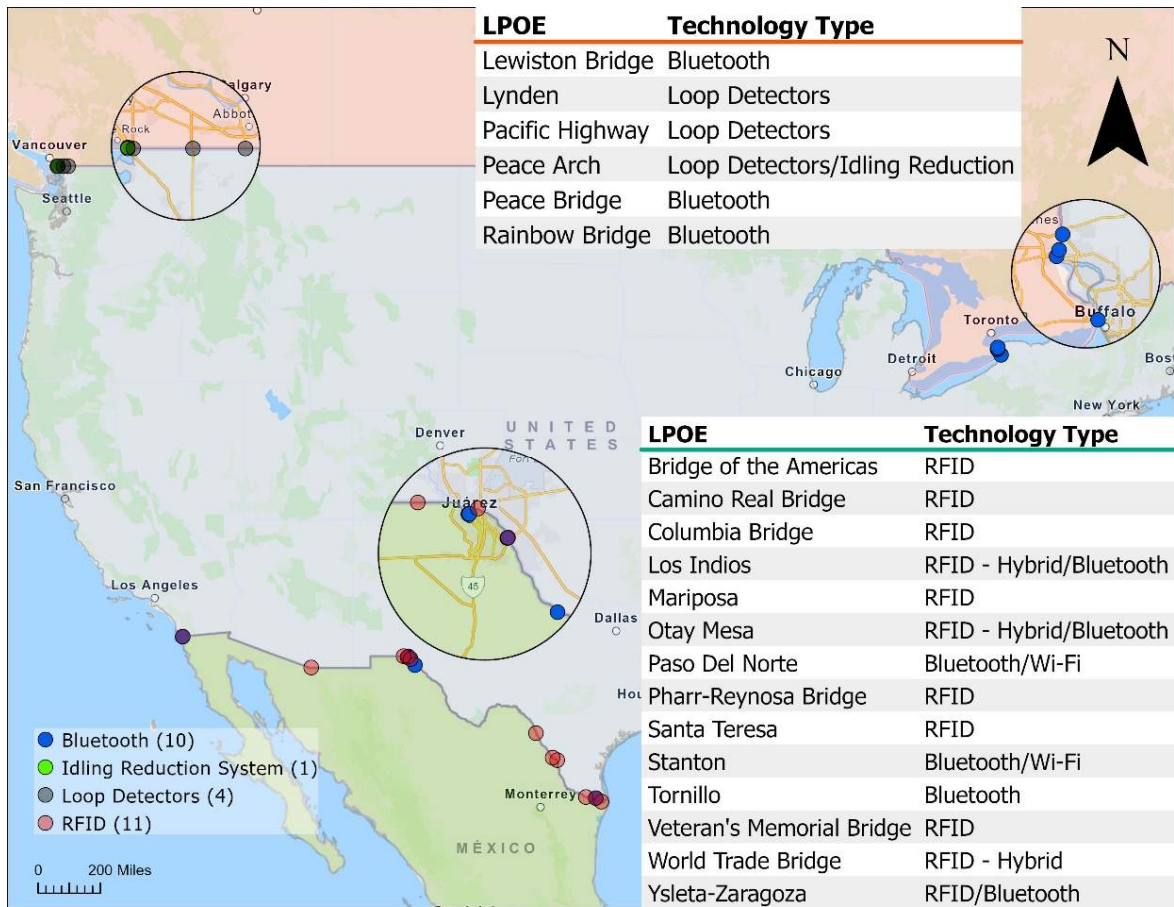

Figure 27. BWT Technology Deployments at Major U.S.-Canada and U.S.-Mexico Border Crossings

Table 4: U.S. Northern and Southern Border Wait Time Systems Summary

POE	Border	Status	Technology Type	Vehicle Type	Installation year	Operating & Maintaining Entities	Website
Otay Mesa	US-MX	Active	RFID - Hybrid/Bluetooth	POV/CMV	2020	IBI and TTI for Caltrans/SANDAG	https://bcis.tti.tamu.edu/
Mariposa	US-MX	Inactive	RFID	CMV	2012	N/A	N/A
Santa Teresa	US-MX	Inactive	RFID	CMV	2015	N/A	N/A
Paso Del Norte	US-MX	Active	Bluetooth/Wi-Fi	POV	2016	TTI for TxDOT and City of El Paso	https://bcis.tti.tamu.edu/
Stanton	US-MX	Active	Bluetooth/Wi-Fi	POV	2016	TTI for TxDOT and City of El Paso	https://bcis.tti.tamu.edu/
Bridge of the Americas	US-MX	Active	RFID	CMV	2008	TTI for TxDOT	https://bcis.tti.tamu.edu/
Ysleta-Zaragoza	US-MX	Active	RFID/Bluetooth	POV/CMV	2010	TTI for TxDOT and City of El Paso	https://bcis.tti.tamu.edu/
Tornillo	US-MX	Active	Bluetooth	POV	2023	TTI for TxDOT	https://bcis.tti.tamu.edu/
Camino Real Bridge	US-MX	Active	RFID	CMV	2018	TTI for TxDOT	https://bcis.tti.tamu.edu/

POE	Border	Status	Technology Type	Vehicle Type	Installation year	Operating & Maintaining Entities	Website
Columbia Bridge	US-MX	Active	RFID	CMV	2012	TTI for TxDOT	https://bcis.tti.tamu.edu/
World Trade Bridge	US-MX	Active	RFID - Hybrid	CMV	2012	TTI for TxDOT	https://bcis.tti.tamu.edu/
Pharr-Reynosa Bridge	US-MX	Active	RFID	CMV	2012	TTI for TxDOT	https://bcis.tti.tamu.edu/
Los Indios	US-MX	Active	RFID - Hybrid/Bluetooth	POV/CMV	2023	TTI for TxDOT	https://bcis.tti.tamu.edu/
Veteran's Memorial Bridge	US-MX	Active	RFID	CMV	2016	TTI for TxDOT	https://bcis.tti.tamu.edu/
Lewiston Bridge	US-CN	Active	Bluetooth	POV/CMV	2016	PBA & NFBC	https://www.nittec.org/
Rainbow Bridge	US-CN	Active	Bluetooth	POV	2017	PBA & NFBC	https://www.nittec.org/
Peace Bridge	US-CN	Active	Bluetooth	POV/CMV	2016	PBA & NFBC	https://www.nittec.org/

POE	Border	Status	Technology Type	Vehicle Type	Installation year	Operating & Maintaining Entities	Website
Peace Arch	US-CN	Active	Loop Detectors/Idling Reduction	POV	2007	BCMOT & WSDOT	https://www.cascadegatewaydata.com
Pacific Highway	US-CN	Active	Loop Detectors	POV/CMV	2007	BCMOT & WSDOT	https://www.cascadegatewaydata.com
Lynden	US-CN	Active	Loop Detectors	POV/CMV	2007	BCMOT & WSDOT	https://www.cascadegatewaydata.com
Sumas	US-CN	Active	Loop Detectors	POV/CMV	2007	BCMOT & WSDOT	https://www.cascadegatewaydata.com

4. REFERENCES

1. Cascade Gateway Border Data Warehouse Upgrade & BIFA Integration Project Report #1 – Project Final Report, Whatcom Council of Governments, September 2011.
2. Cascade Gateway Border Data Warehouse 3.0 Design Document, Whatcom Council of Governments, February 2021.
3. Concept of Operations for the Cascade Gateway Border Data Warehouse 3.0 Upgrade, Whatcom Council of Governments, May 2020.
4. Border Advance Traveler Information System (ATIS) System Operation Report, BCMOTI, April 2020.
5. I-5 Blaine Customs Facility ITS Improvements – ITS Plan, WSDOT, April 2002.
6. Advanced Traveler Information System – Route 99 and Route 15 Southbound – Electrical Installation Plan, Lighting Installation Plan, BCMOTI, March 2005.
7. SR 543 I-5 to International Boundary Widening & Border X-ing Improvements – ITS Plan, WSDOT, October 2005.
8. Highway 15 – FAST Lane Improvements – 175A Street – USA / Canada Border – Signal and Lighting Installation Plan, BCMOTI, November 2012.
9. SR 539 Lynden Aldergrove Port of Entry Improvements – ITS Plan, WSDOT, February 2014.
10. ATIS Installation – Highway 11 (Sumas Way) & Highway 13 (264 Street) – Highway 13 – 8 Avenue to USA Border Crossing Aldergrove – Signal & Lighting Installation Plan, ATIS Installation Plan, BCMOTI, April 2018.
11. SR 9 & SR 539 Advanced Traveler Information System (ATIS) – ITS Plan, WSDOT, November 2013.
12. ATIS Installation – Highway 11 (Sumas Way) & Highway 13 (264 Street) – Highway 11 – From Vye Road to USA Border Crossing Abbotsford – ATIS Installation Plan, BCMOTI, June 2012.
13. Proposal for WCOG Cascade Gateway ABIS Design Project, Transpo Group, September 2023.
14. Cascade Gateway Advanced Border Information System Design Project (ABIS) Request for Proposals, Whatcom Council of Governments, August 2023.
15. 2023-12-12 - Cascade Gateway ABIS Design Project Kickoff Meeting – Minutes, Transpo Group, December 2023.
16. <https://cascadegatewaydata.com/Dashboard>. Accessed 2024-02-15.
17. <https://www.th.gov.bc.ca/atiss/>. Accessed 2024-02-15.
18. <https://www.gsa.gov/about-us/gsa-regions/region-10-northwestarctic/buildings-and-facilities/washington/pacific-highway-land-port-of-entry>. Accessed 2024-02-15.
19. <https://www.gsa.gov/about-us/gsa-regions/region-10-northwestarctic/buildings-and-facilities/washington/kenneth-g-ward-land-port-of-entry>. Accessed 2024-02-15.
20. <https://www.gsa.gov/about-us/gsa-regions/region-10-northwestarctic/buildings-and-facilities/washington/sumas-land-port-of-entry>. Accessed 2024-02-15.
21. <https://www.cbsa-asfc.gc.ca/travel-voyage/lbcp-pptf-eng.html>. Accessed 2024-02-15.
22. <https://www.highway99tunnel.ca/>. Accessed 2024-02-15.